

# CONTRACTOR PRICE LIST



# UCAN

FASTENING PRODUCTS

## MASONRY DRILL BITS & CHISELS

- Uni-Plus for Cordless Tools
- Straight Shank Percussion Bits
- SDS Plus Bits
- Spline Shank Bits and Chisels
- SDS Max Bits and Chisels
- Core Bits
- Chisels for Kango
- Screwdriver Accessories

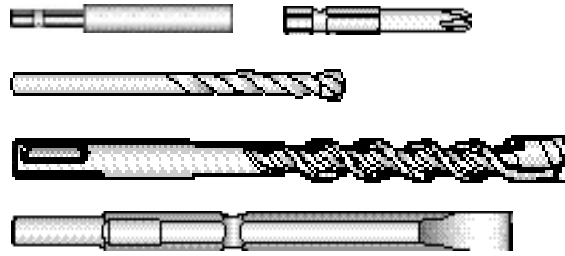

1 - 4

## ADHESIVE ANCHORING

- Flo-Rok Epoxy Injection Systems
- Flo-Rok 5 MAX - All-weather Injection System
- Adhesive Capsule System
- Rod Assemblies
- Rockite
- Rod Couplings



5 - 8

## MEDIUM & HEAVY DUTY ANCHORS

- Wedge Anchors
- Heavy Load Anchors
- Drop-in Anchors
- Sleeve Anchors
- Lag Shields
- Single Expansion Shields
- Double Expansion Shields

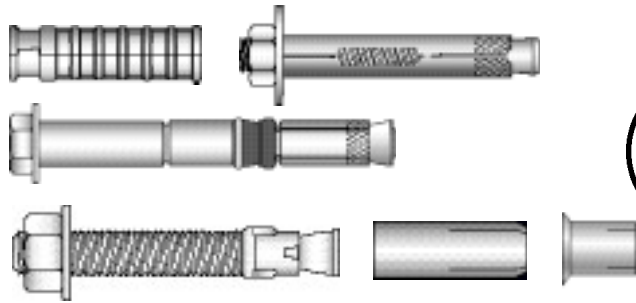

9 - 11

## LIGHT DUTY ANCHORS

- Zamac Pin Bolts
- Nylon Pin Bolts
- Screw Plugs
- Drive Screw Anchors
- Lead Screw Anchors
- Renovation Anchor
- MJP Insulation Fasteners
- Metal Frame Anchor

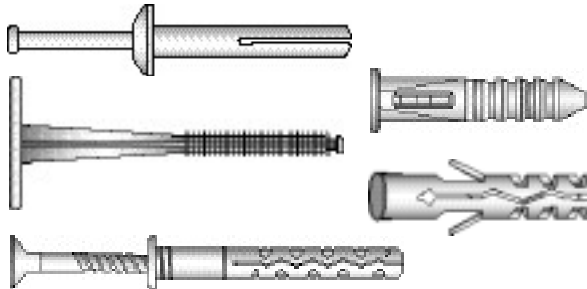

12 - 13

## HOLLOW WALL ANCHORS

- Twister
- Toggle Bolts
- Metal Hollow Wall Anchors
- Nylon Toggle

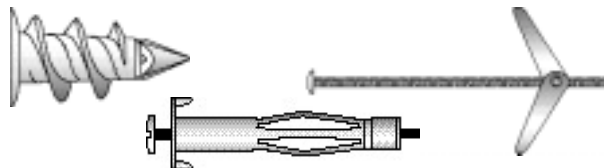

14

## SPECIALTY ANCHORS

- U-Drive
- Scru-it
- Cast-in Place Anchors
- Stress Plates

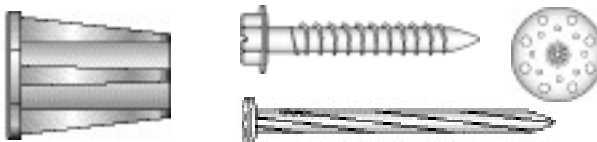

15 - 17

## DIRECT FASTENING

Low velocity tools  
Power loads  
Pins and Studs for all makes  
Conduit clip assembly

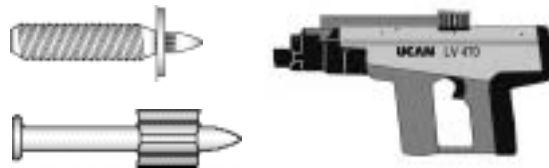

18 - 20

## SELF DRILLING SCREWS AND ACCESSORIES

Metal to metal fasteners  
Wood to metal fasteners  
Metal to wood fasteners  
CB Screws  
Sealing Washers

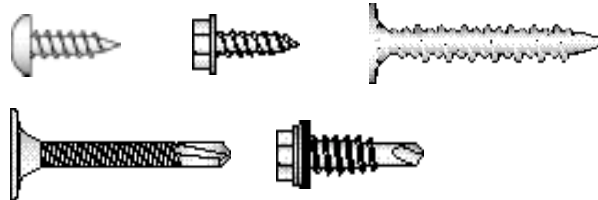

21 - 25

## TECHNICAL DATA

Metal Screws  
Anchors  
Mechanical & Chemical Anchors

26 - 28

UCAN PRODUCTS ARE SUPPLIED EXCLUSIVELY BY DISTRIBUTORS COAST TO COAST. ALL PRODUCTS ARE SUBJECT TO ALL APPLICABLE SALES TAXES.

## FASTENER SELECTION GUIDELINES

Ucan Fastening Products' anchoring line ranges from light duty plastic anchors to the most technically advanced types of heavy load anchors. This wide variety of high quality fasteners provides the user with the flexibility to select the anchor best suited for the application. For this reason, prior to selecting the type, size and quantity of fasteners required, the following factors should be considered:

- Type and the condition of the base material
  - Installation procedure
  - Corrosion considerations
  - The desired load transfer by the fastener to the base material
  - Dimensions of the base material
  - Anchor spacing and edge distance
  - Safety factor required
  - Type of load(s) acting on the fastener (eg:static, dynamic, seismic)
- In all applications, the design engineer or architect responsible for the project should verify the load bearing capacity and other performance criteria.
- UCAN fasteners are designed to minimize the influence of the installation technique on the anchor's holding power. However, basic installation procedures listed for each anchor in our technical and sales literature should be followed, to ensure the integrity of the anchoring assembly.
- Correct hole geometry is important to guarantee published load performance. The UCAN carbide drill bit, manufactured to ISO and ANSI standards, will produce holes which

are optimal for metric or fractional anchors. Incorrect hole geometry can cause reduced holding power, and installation difficulties.

- Hole cleaning is an important and easy step to ensure maximum anchor performance. For most expansion and chemical anchors, cleaning the hole with a nylon brush and blow out bulb/pump is all that is required. These steps will remove concrete dust and debris from the hole which could reduce the effectiveness of the anchor.
- After placement of the anchor, turning the nut or hex bolt tightens down the assembly. For engineered or critical applications, specific torque should be applied using a calibrated torque wrench.

A safety factor must be used to compensate for variations in loading, material strength and installation conditions and to ensure minimum anchor displacement. It is the designer's responsibility to analyze all conditions and select the appropriate safety factor.

For predominantly static loading in non-critical applications, UCAN recommends the following safety factors:

- For mechanical and chemical anchors 4:1
- For plastic anchors 5:1
- For PA system in concrete 8:1
- For PA system in steel 5:1

Tables showing typical allowable working loads for most UCAN anchors appear on pages 26-28.

For more information or safety factors on performance factors for Limit State Design please contact UCAN Technical Department.

## UCAN QUALITY and PRECISION

Ucan drill bits are manufactured from the highest quality materials and they are carefully checked at each production stage to ensure compliance with specifications.

Correct drill sizing is extremely important because the performance of many types of concrete anchors can be adversely affected by inaccurate hole diameters .

All Ucan inch fractional drill sizes are made to strict ANSI specifications. Metric sizes adhere to the appropriate ISO standards.

## UNI PLUS FOR CORDLESS DRILLS



**Drills quickly and quietly through most types of masonry without percussion noise.**

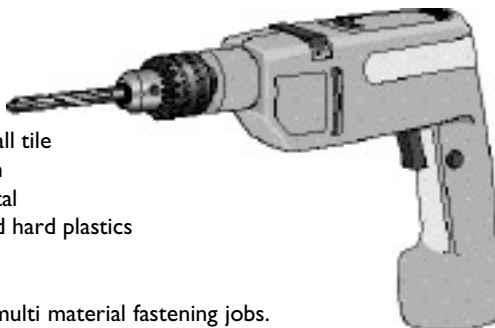

Also drills:

- Glazed wall tile
  - Aluminum
  - Sheet metal
  - Wood and hard plastics
- Ideal for multi material fastening jobs. e.g. wood, metal, or plastic to masonry.
  - Ideal for use in occupied buildings where percussion noise is very disturbing.
  - Unique PLUS POINT carbide tip is self centering, requires up to 50% less drilling PRESSURE AND IS EXCEPTIONALLY hard wearing.
  - Patented TURBO fluting removes drilling debris quickly to ensure optimum efficiency.

**PLEASE NOTE:**  
UNI-PLUS BITS SHOULD NEVER BE USED WITH PERCUSSION

Part no.	Size	Price /ea.
JUP 5323	5/32 X 3-1/8	
JUP 3163	3/16 X 3-1/2	
JUP 144	1/4 X 4-1/8	
JUP 5165	5/16 X 4-3/4	

## MASONRY DRILL BITS\*

### TYPE "D" STRAIGHT SHANK, ROTARY-PERCUSSION



**Faster drilling + long life = lowest cost per hole**

UCAN Type "D" bits cost less per hole because they are engineered to deliver peak performance in modern hammer drills which operate at both high RPM and high percussion rates.

Part No.	Diameter (in)	(mm)	Length (in)	Shank Dia.	Pkg. Qty.	Price /ea.
JOD 183	1/8	3	2-3/4	1/8	10	
JOD 5323	5/32	4	3-1/2	5/32	10	
JOD 11643	11/64	4.5	3-1/4	11/64	10	
JOD 3163	3/16	5	3-1/2	3/16	10	
JOD 3166	3/16	5	6	3/16	10	
JOD 7323	7/32	5.5	3-3/4	7/32	10	
JOD 15644	15/64	6	4	15/64	10	
JOD 15646	15/64	6	6	15/64	10	
JOD 144	1/4	6.5	4-1/8	1/4	10	
JOD 146	1/4	6.5	6	1/4	10	
JOD 1413	1/4	6.5	13	1/4	10	
JOD 1416	1/4	6.5	16	1/4	10	
JOD 1420	1/4	6.5	20	1/4	10	
JOD 9324	9/32	7	4-3/8	9/32	10	
JOD 9326	9/32	7	6	9/32	10	
JOD 5164	5/16	8	4-3/4	5/16	10	
JOD 5168	5/16	8	7-7/8	5/16	10	
JOD 51616	5/16	8	16	5/16	10	
JOD 51624	5/16	8	24	5/16	10	
JOD 385	3/8	9.5	5-3/8	3/8	10	
JOD 3813	3/8	9.5	13	3/8	10	
JOD 3816	3/8	9.5	16	3/8	10	
JOD 3820	3/8	9.5	20	3/8	10	
JOD 3824	3/8	9.5	24	3/8	10	
JOD 3839	3/8	9.5	39	3/8	10	
JOD 25648	25/64	10	8	3/8	10	
JOD 256416	25/64	10	16	3/8	10	
JOD 7166	7/16	11	6	3/8	10	
JOD 15326	15/32	12	6	3/8	10	
JOD 153213	15/32	12	13	3/8	10	
JOD 126	1/2	13	6	3/8	10	
JOD 1213	1/2	13	13	3/8	10	
JOD 1216	1/2	13	16	3/8	10	
JOD 1220	1/2	13	20	3/8	10	
JOD 1224	1/2	13	24	3/8	10	
JOD 9166	9/16	14	6	3/8	10	
JOD 586	5/8	16	6	3/8	5	
JOD 5813	5/8	16	13	3/8	5	
JOD 5816	5/8	16	16	1/2	5	
JOD 5824	5/8	16	24	1/2	5	
JOD 11166	11/16	17	6	1/2	5	
JOD 346	3/4	19	6	1/2	5	
JOD 3413	3/4	19	13	1/2	5	
JOD 3416	3/4	19	16	1/2	5	
JOD 3420	3/4	19	20	1/2	5	
JOD 25326	25/32	20	6	1/2	5	
JOD 786	7/8	22	6	1/2	5	
JOD 7813	7/8	22	13	1/2	5	
JOD 7816	7/8	22	16	1/2	5	
JOD 7824	7/8	22	24	1/2	5	
JOD 16	1	26	6	1/2	2	
JOD 113	1	26	13	1/2	2	
JOD 116	1	26	16	1/2	2	
JOD 11816	1-1/8	28	16	1/2	2	
JOD 11416	1-1/4	32	16	1/2	2	
JOD 13816	1-3/8	35	16	1/2	2	

## SDS PLUS SPEEDHAMMER\*

A NEW GENERATION HIGH PERFORMANCE DRILL BIT



LONGER DRILL BIT LIFE • BETTER OPERATOR COMFORT  
FASTER DRILLING AND DUST REMOVAL



Part No.	Diameter		Length (in)		Price /ea.
	(in)	(mm)	Overall	Usable	
SDS 5324	5/32	4	4-1/8	2	
SDS 5325	5/32	4	5-1/4	3	
SDS 5326	5/32	4	6-1/2	4-1/4	
SDS 3164	3/16	5	4	2	
SDS 3166	3/16	5	6	4	
SDS 7324	7/32	5.5	4	2	
SDS 7326	7/32	5.5	6	4	
SDS 15644	15/64	6	4	2	
SDS 15646	15/64	6	6	4	
SDS 144	1/4	6.5	4	2	
SDS 146	1/4	6.5	6	4	
SDS 149	1/4	6.5	9	6-3/4	
SDS 1412	1/4	6.5	12	10	
SDS 1418	1/4	6.5	18	16	
SDS 9326	9/32	7	6	4	
SDS 5164	5/16	8	4	2	
SDS 5166	5/16	8	6	4	
SDS 5168	5/16	8	8	5-3/4	
SDS 386	3/8	9.5	6	4	
SDS 389	3/8	9.5	9	7	
SDS 3812	3/8	9.5	12	10	
SDS 3818	3/8	9.5	18	16	
SDS 3824	3/8	10	24	22	
SDS 25646	25/64	10	6	4	
SDS 25648	25/64	10	8	6	
SDS 7166	7/16	11	6	4	
SDS 15326	15/32	12	6	4	
SDS 15329	15/32	12	9	7	
SDS 153224	15/32	12	24	22	
SDS 126	1/2	13	6	4	
SDS 129	1/2	13	9	7	
SDS 1212	1/2	13	12	10	
SDS 1218	1/2	13	18	16	
SDS 9166	9/16	14	6	4	
SDS 9168	9/16	14	8	6	
SDS 19329	19/32	15	9	7	
SDS 586	5/8	16	6	4	
SDS 589	5/8	16	9	7	
SDS 5812	5/8	16	12	10	
SDS 5818	5/8	16	18	16	
SDS 5824	5/8	16	24	22	
SDS 456412	45/64	18	12	10	
SDS 349	3/4	19.1	9	7	
SDS 3412	3/4	19.1	12	10	
SDS 3418	3/4	19.1	18	16	
SDS 25328	25/32	20	8	6	
SDS 253218	25/32	20	18	16	
SDS 27326	27/32	21.4	6	4	
SDS 7812	7/8	22	12	10	
SDS 616412	61/64	24	12	10	
SDS 636412	63/64	25	12	10	
SDS 112	1	25.4	12	10	
SDS 118	1	25.4	18	16	

\*All diameters 3/16" - 5/8" are Speedhammer except lengths in excess of 12"

## SDS PLUS DRILL BITS BULK PACK IN REUSABLE PLASTIC CASE

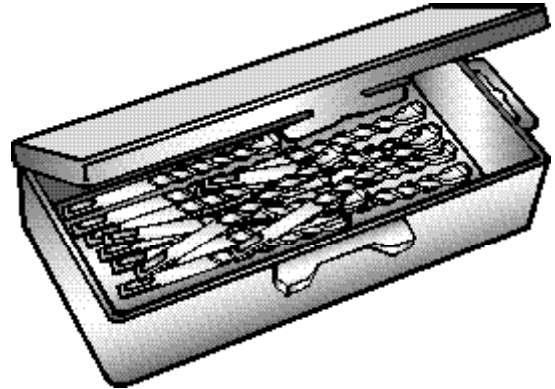

Part No.	Diameter		Length (in)		Pkg. Qty.	Price /ea.
	(in)	(mm)	Overall	usable		
SDB 3164	3/16	5	4	2	25	
SDB 3166	3/16	5	6	4	25	
SDB 144	1/4	6.5	4	2	25	
SDB 146	1/4	6.5	6	4	25	
SDB 5164	5/16	8	4	2	25	
SDB 5166	5/16	8	6	4	25	
SDB 386	3/8	9.5	6	4	25	
SDB 15326	15/32	12	6	4	20	
SDB 126	1/2	13	6	4	20	

## ADAPTORS FOR SDS PLUS BITS



Part no.	Description	Price /ea.
JOM SDS	SDS MAX to SDS adaptor	
JOS SDS	Spline to SDS adaptor	
JOH SDS	TE-F to SDS adaptor	
JOP SDS	747 (hex) to SDS adaptor	

## FOR STRAIGHT SHANK BITS

Permits use of key chucks with SDS hammers

SDS KC	SDS to 1/2" - 20 for key chuck
--------	--------------------------------

## CHISELS FOR KANGO FOR MODELS 900 AND 950

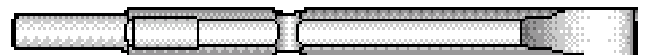

Part no.	Description	Price /ea.
CHI K12	12 x 1 Cold Chisel	
CHI K15	15 x 1 Cold Chisel	
CHI K18	18 x 1 Cold Chisel	
CHP K12	12 Bull Point	
CHP K15	15 Bull Point	
CHP K18	18 Bull Point	

## SDS-MAX DRILL BITS



**\*4 tips for faster drilling (12mm and 1/2" dia. are 2 tip)**

Part No.	Diameter		Length (in)		Price /ea.
	(in)	(mm)	Overall	Usable	
MAX 153213	15/32	12	13	7	
MAX 1213	1/2	13	13	7	
MAX 5813	5/8	16	13	7	
MAX 5821	5/8	16	21	15	
MAX 456413	45/64	18	13	7	
MAX 3413	3/4	19.1	13	7	
MAX 3421	3/4	19.1	21	15	
MAX 3436	3/4	19.1	36	31	
MAX 253213	25/32	20	13	7	
MAX 7813	7/8	22	13	8	
MAX 7821	7/8	22	21	16	
MAX 616413	61/64	24	13	8	
MAX 636413	63/64	25	13	8	
MAX 113	1	25.4	13	8	
MAX 121	1	25.4	21	16	
MAX 136	1	25.4	36	31	
MAX 11815	1-1/8	28	15	10	
MAX 11823	1-1/8	28	23	18	
MAX 11415	1-1/4	32	15	10	
MAX 11423	1-1/4	32	23	18	
MAX 11436	1-1/4	32	36	31	
MAX 13823	1-3/8	36	23	18	
MAX 11223	1-1/2	38	23	18	

## SPLINE SHANK BITS



Part No.	Diameter		Length (in)		Price /ea.
	(in)	(mm)	Overall	Usable	
JOS 153211	15/32	12	11	6	
JOS 1210	1/2	13	10	5	
JOS 1216	1/2	13	16	11	
JOS 5810	5/8	16	10	5	
JOS 5816	5/8	16	16	11	
JOS 456416	45/64	18	16	11	
JOS 3416	3/4	19	16	11	
JOS 3422	3/4	19	22	17	
JOS 253216	25/32	20	16	11	
JOS 7816	7/8	22	16	11	
JOS 7822	7/8	22	22	17	
JOS 616416	61/64	24	16	11	
JOS 636416	63/64	25	16	11	
JOS 111	1	25.4	11	6	
JOS 116	1	25.4	16	11	
JOS 122	1	25.4	22	17	
JOS 127	1	25.4	27	22	
JOS 11816	1-1/8	28	16	11	
JOS 11822	1-1/8	28	22	17	
JOS 131616	1-3/16	30	16	11	
JOS 11416	1-1/4	32	16	11	
JOS 11422	1-1/4	32	22	17	
JOS 13816	1-3/8	35	16	11	
JOS 13822	1-3/8	35	22	17	
JOS 11216	1-1/2	38	16	11	
JOS 11222	1-1/2	38	22	17	

## CHISELS

FOR SDS-MAX HAMMERS

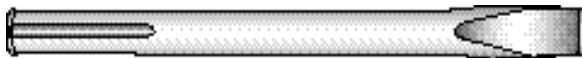

Part No.	Description	Price /ea.
CHI M11	11" x 1" Cold chisel	
CHI M16	16" x 1" Cold chisel	
CHP M11	11" Bull point	
CHP M16	16" Bull point	
CHS M11	11" x 3" Scaling Chisel	
CHS M16	16" x 2" Scaling Chisel	

## 4 TIP SPLINE BITS

**Drills true round holes.  
15% - 20% faster drilling  
than single tip bits.**



Part No.	Diameter		Length (in)		Price /ea.
	(in)	(mm)	Overall	Usable	
J4S 3416	3/4	19.1	16	11	
J4S 253216	25/32	20	16	11	
J4S 7816	7/8	22	16	11	
J4S 636416	63/64	25	16	11	
J4S 116	1	25.4	16	11	
J4S 131616	1-3/16	30	16	11	
J4S 13423	1-3/4	45	23	18	
J4S 223	2	50	23	18	

## CHISELS FOR HILTI OLDER MODELS

TO FIT TE52,TE60,TE72 AND TE92



Part No.	Description	Price /ea.
CHI T14	14 X 1 Cold chisel	
CHI T20	20 X 1 Cold chisel	
CHP T14	14 Bull point	

## CHISELS

FOR SPLINE SHANK HAMMERS



Part No.	Description	Price /ea.
CHI A12	12 x 1 Cold Chisel	
CHI A18	18 x 1 Cold Chisel	
CHP A12	12 Bull Point	
CHP A18	18 Bull Point	
A245295	12 X 2 Scaling chisel	

## CORE BITS

FOR SPLINE,SDS MAX & KANGO TAPER SHANKS



Part No.	Diameter		Length (in)	Price /ea.
	(in)	(mm)		
DU6 CB138	1-3/8	35	4	
DU6 CB1916	1-9/16	40	4	
DU6 CB2	2	52	4	
DU6 CB212	2-1/2	66	4	
DU6 CB234	2-3/4	70	4	
DU6 CB318	3-1/8	80	4	
DU6 CB312	3-1/2	90	4	
DU6 CB4	4	100	4	
DU6 CB438	4-3/8	110	4	
DU6 CB5	5	125	4	

## ACCESSORIES



Part No.	Description	Price /ea.
KAN S16	16" Core Bit Shank - Kango 950	
MAX S8	8" Core Bit Shank - SDS MAX	
MAX S18	18" Core Bit Shank - SDS MAX	
A 245968	8" Core Bit Shaft - Spline	
A 245969	16" Core Bit Shaft - Spline	
A 245967	Starter Bit	
A 604214	Drift key	

For adaption to other shanks please check with our order desk.

## SCREWDRIVER ACCESSORIES

### MAGNETIC NUT SETTERS



MNS 14S	1/4 x 1-11/16 Mag nut setter	10
MNS 516S	5/16 x 1-11/16 Mag nut setter	10
MNS 38S	3/8 x 1-3/4 Mag nut setter	10
MNS 716S*	7/16 x 1-3/4 Mag nut setter	10
MNS 14	1/4 x 2-1/2 Mag nut setter	10
MNS 516*	5/16 x 2-1/2 Mag nut setter	10
MNS 38	3/8 x 2-1/2 Mag nut setter	10
MNS 716*	7/16 x 2-1/2 Mag nut setter	10

### MAGNETIC BIT HOLDERS

Stainless Steel



MBH 3	1/4 x 3 Magnetic bit holder bit	10
-------	---------------------------------	----

### QUICK CHANGE BIT HOLDER

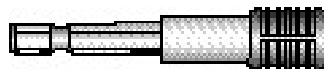

MBH 25Q	1/4 x 2-1/2 Quick change magnetic bit holder	
---------	--	--

## SCREWDRIVER ACCESSORIES

### PHILLIPS BITS



Part No.	Description	Standard Pack	Price /ea.
PB11	No. 1 x 1 Phillips bit	25	
PB21	No. 2 x 1 Phillips bit	25	
PB31	No. 3 x 1 Phillips bit	25	
PB12	No. 1 x 2 Phillips bit	25	
PB22	No. 2 x 2 Phillips bit	25	
PB32	No. 3 x 2 Phillips bit	25	
PB13	No. 1 x 3 Phillips bit	25	
PB23	No. 2 x 3 Phillips bit	25	
PB33	No. 3 x 3 Phillips bit	25	
PB14	No. 1 x 4 Phillips bit	25	
PB24	No. 2 x 4 Phillips bit	25	
PB34	No. 3 x 4 Phillips bit	25	
PB16*	No. 1 x 6 Phillips bit	1	
PB26	No. 2 x 6 Phillips bit	1	
PB36	No. 3 x 6 Phillips bit	1	

### DRYWALL BITS - REDUCED SHANK



PR21	No. 2 x 1 Phillips bit - reduced shank	25
------	--	----

### SQUARE RECESS BITS



RB01	No. 0 x 1 Square recess bit	25
RB11	No. 1 x 1 Square recess bit	25
RB21	No. 2 x 1 Square recess bit	25
RB31	No. 3 x 1 Square recess bit	25
RB02	No. 0 x 2 Square recess bit	25
RB12	No. 1 x 2 Square recess bit	25
RB22	No. 2 x 2 Square recess bit	25
RB32	No. 3 x 2 Square recess bit	25
RB13	No. 1 x 3 Square recess bit	25
RB23	No. 2 x 3 Square recess bit	25
RB33	No. 3 x 3 Square recess bit	25
RB14	No. 1 x 4 Square recess bit	25
RB24	No. 2 x 4 Square recess bit	25
RB34	No. 3 x 4 Square recess bit	25
RB16*	No. 1 x 6 Square recess bit	1
RB26	No. 2 x 6 Square recess bit	1
RB36	No. 3 x 6 Square recess bit	1

### SLOTTED BITS



SL22	7/32 x 2 Slotted bit	1
------	----------------------	---

## FLO-ROK 1 and 3

### EPOXY INJECTION ANCHORING SYSTEM

- Completely stress free - may be used close to edges
- Excellent performance under dynamic loads
- Convenient dual cartridges dispense exact proportions of resin and hardener
- Partially used cartridges can be stored for later use

### FLO-ROK EPOXY CARTRIDGES STANDARD SIZE 22 oz CARTRIDGES



Part No.	Description	Case Qty.	Case Wt.	Price /ea.
FR1-22	regular cure	10	24	
FR3-22	fast cure	10	21	

• Cartridge price includes 1 Static mixing nozzle

### STATIC MIXING NOZZLES

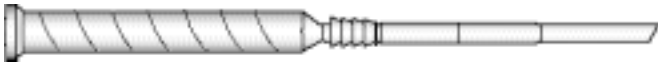

Part No.	Description	Price /ea.
PAM 5838T	5/8" - 3/8" Mixing Nozzle with Extension	

### ACCESSORIES

PAM 501	Nozzle Coupling Nut
A247120	Blow Out Bulb
BOP 100	Blow Out Pump
FRBR1	3/8" - 1/2" Nylon Brush
FRBR2	1/2" - 1" Nylon Brush

### DISPENSING TOOLS

#### STANDARD SIZE 22 oz CARTRIDGES

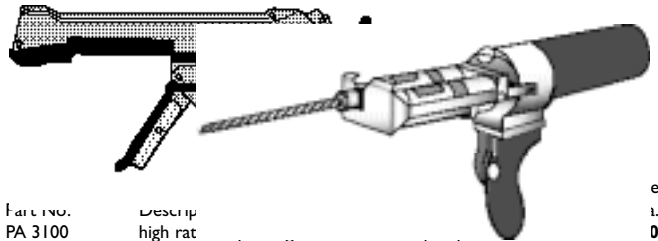

Part No.	Description	Price /ea.
PA 3100	high rat	0
PA 4000	pneumatic dispensing tool	690.00

### CURE TIMES

FR1		FR3	
TEMPERATURE	TIME	TEMPERATURE	TIME
over 27°C (80°F)	6 hrs.	over 38°C (100°F)	25 min.
16-27°C (60-80°F)	12 hrs.	24-38°C (75-100°F)	45 min.
4-16°C (40-60°F)	24 hrs.	4-24°C (40-75°F)	75 min.

Note: Do not disturb rod after 5 minutes.

## FLO-ROK 5

### ADVANCED POLYESTER INJECTION SYSTEM

- Works best at warmer temperatures (above 15°C)
- Slower gel time than FR5-Max
- Excellent for both solid & hollow wall applications
- Can be used with low cost plastic screens

### FLO-ROK 5 CARTRIDGES



Part No.	Description	Case Qty.	Case Wt.	Price /ea.
FR5-28	28oz cartridge	5	18	

Cartridge price includes 1 Static mixing nozzle.

### STATIC MIXING NOZZLES WITH A SNAP-OFF PILOT END



Part No.	Description	Price /ea.
PAM 5838T	5/8" - 1/2" mixing nozzle w/extension for Fr 5-28	

### SCREENS FOR FR-5 FOR HOLLOW WALL APPLICATIONS (Not suitable for use with FR5-MAX)



Plastic - w/centering plug

Part No.	Max. rod dia.	Screen Size (mm)	Drill dia.(mm)	Price /C
PLC 1245	5/16	12 X 45	12	
PLC 1260	5/16	12 X 60	12	
PLC 1280	5/16	12 X 80	12	
PLC 1685	3/8	16 X 85	16	
PLC 16130	3/8	16 X 130	16	
PLC 2085	5/8	20 X 85	20	

DISPENSING TOOLS - SEE OPPOSITE PAGE  
ROD ASSEMBLIES - SEE PAGE 8

### CURE TIMES

TEMPERATURE (°C)	FR5
+10°C	1.5 hrs.
+20°C	1 hrs.
+30°C	45 min.

Note: Do not disturb rod after 5 minutes.



## FLO-ROK 5 MAX

NEW LOW ODOUR FORMULA FOR YEAR ROUND USE

- Advanced epoxy acrylic formula can be dispensed at winter temperatures as low as -20°C without preheating
- Excellent for both solid and hollow wall applications
- User Friendly - does not contain MMA (methyl methacrylate)
- Smooth flowing, non-drip, easy to control, long shelf life

### FLO-ROK 5 MAX CARTRIDGES



Part No.	Size	Qty.	Case Wt.	Price /ea.
FR5-5 MAX	5.5 oz	10	7	
FR5-12 MAX	12.2 oz	12	18	
FR5-28 MAX	28 oz	5	17	

• Cartridge price includes 1 Static mixing nozzle

### STEEL SCREENS FOR FR5 MAX FOR HOLLOW

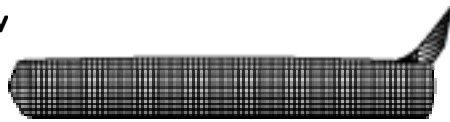

Part No.	Max. rod dia. (inches)	Screen Size (mm)	Drill dia. (inches)	Price /ea.
SFR 383	3/8	1/2 X 3	1/2	
SFR 386	3/8	1/2 X 6	1/2	
SFR 3810	3/8	1/2 X 10	1/2	
SFR 123	1/2	5/8 X 3	5/8	
SFR 126	1/2	5/8 X 6	5/8	
SFR 1210	1/2	5/8 X 10	5/8	
SFR 583	5/8	3/4 X 3	3/4	
SFR 586	5/8	3/4 X 6	3/4	
SFR 5810	5/8	3/4 X 10	3/4	
SFR 5813	5/8	3/4 X 13	3/4	

### ROD ASSEMBLIES - SEE PAGE 8

FULL CURE TIMES	+30°C	20°C	5°C	0°C	-20°C
	45 min.	1 hr	3 hrs	4 hrs	10 hrs

Important: Anchor rods should be installed immediately after FLO-ROK 5 MAX has been dispensed. They should not be disturbed until fully cured.

### DISPENSING TOOLS

FOR 12 & 28 oz CARTRIDGES

(5.5 oz cartridge is used with standard caulking tool)



PA 3400



PA 1200

Part No.	Description	Price /ea.
PA1200	12oz. manu	
PA3400	28oz. manua. dispensing tool	
PA4400	28oz. pneumatic dispensing tool	

### STATIC MIXING NOZZLES

WITH A SNAP-OFF PILOT END

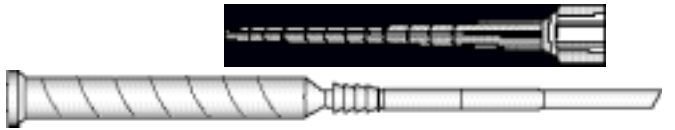

Part No.	Description	Price /ea.
PAM 38	Mixing Nozzle for FR5-5 MAX & FR5-12 MAX	
PAM 1238	Mixing Nozzle for FR5-28 MAX	

### ACCESSORIES

PAM 505	Nozzle Coupling Nut
A247120	Blow Out Bulb
BOP 100	Blow Out Pump
FRBR1	3/8" - 1/2" Nylon Brush
FRBR2	1/2" - 1" Nylon Brush

FLO-ROK FR5 MAX (B7 rod)	INSTALLATION DATA				LOAD DATA IN 5000 psi (35 MPa) CONCRETE			
	SIZE (inch)	HOLE DIAMETER (inch)	EMBEDMENT (inch)	MAXIMUM TORQUE (ft.lbs)	ALLOWABLE LOADS (lbs)		ULTIMATE LOADS (lbs)	
					TENSION (BOND)	STEEL STRENGTH	TENSION (BOND)	SHEAR (STEEL STRENGTH)
	3/8	1/2	3-1/2	15	2,589	2,347	10,354	5,522
	1/2	5/8	4-1/2	30	4,861	4,172	19,443	9,817
	5/8	3/4	5-1/2	60	6,504	6,519	26,016	15,340
	3/4	7/8	6-1/2	110	9,049	9,388	36,195	22,089
	7/8	1	7-1/2	135	-	12,778	-	30,066
	1	1-1/8	8-1/2	185	11,318	16,690	45,272	39,270

## HAMMERCAP SYSTEM™

- **Fastest, easiest, most economical way to install threaded rod and reinforcing bar.**
- **Glass capsule contains pre-measured components to produce optimum strength - perfect results every time.**
- **No rotation of rod/bar required - simply place Hammer cap into prepared hole and drive in the dowel with a hammer or rod driver - THAT'S IT.**
- **Minimum environmental impact - no discarded resin cartridges or wasted material to clean up.**

### HAMMER CAPS™ CAPSULES USE WITH STRAIGHT CUT ROD ASSEMBLY



HAC10-20



HAC 20L-30

Part No.	Size	Threaded Rod Dia.	Drill Size	Hole depth for Threaded Rod	Case Qty.	Price /C
HAC 10	M10 X 90	3/8	7/16	3-1/2	10	
HAC 12	M12 X 95	1/2	9/16	4	10	
HAC 16	M16 X 125	5/8	3/4	5	10	
HAC 20	M20 X 115	3/4	7/8	5	10	
HAC 20L	M20 X 175	3/4	7/8	6-3/4	6	
HAC 24	M24 X 210	1	1-1/8	8	6	
HAC 30	M30 X 260	1-1/4	1-1/2	13	6	

### ROD DRIVERS FOR HAMMER CAP

Part No.	Description	Price /ea.
HCD SDS 25	1" Driver head for SDS hammers (use with SDS KC shank)	
HCD RH 25	1" Driver head for roto hammers (use with A245968 or DU6CBS shank)	
HCD RH 32	1-1/4" Rod driver head for MAX SCH shank	

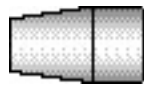

### SHANKS FOR ROD DRIVERS

Part No.	Description	Price /ea.
SDS KC	Shank for SDS hammers	
MAX SHC	Shank for SDS MAX hammers	
A 245968	Shank for Spline drive hammers	



### TABLE FOR REBAR INSTALLATION

Metric rebar	Drilled hole dia.(in)	Approx.Overall rebar dia.(in)	Embedment (in)	Hammer caps required
10 M	9/16	1/2	4 8	1 x HAC 12 2 x HAC 12
15M	3/4	11/16	5 10	1 x HAC 16 2 x HAC 16
20M	61/64	13/16	5 7-1/4	1 x HAC 20 1 x HAC 20L
25M	1-1/4	1-1/16	8 16	1 x HAC 24 2 x HAC 24

## ADHESIVE CAPSULE SYSTEM

- **Convenient glass capsule contains resin, hardener, and quartz aggregate**
- **Exceptionally high anchoring power**
- **Stress free anchoring - may be used close to edges**
- **Ideal for dynamic loads**

### ADHESIVE CAPSULES USE WITH ANGLE CUT ROD ASSEMBLY



Part No.	Size (mm)	Rod Dia.	Min. Depth	Drill Size	Pkg. Qty.	Price /C
ADH C10	M-10 x 80	3/8	3-1/2	1/2	10	
ADH C12	M-12 x 95	1/2	4-1/4	5/8	10	
ADH C16	M-16 x 95	5/8	5	3/4	10	
ADH C20	M-20 x 120	3/4	6-3/4	7/8	10	
ADH C20L	M-20 x 175	7/8	7-1/2	1	6	
ADH C24	M-24 x 210	1	8-1/4	1-3/16	6	
ADH C30	M-30 x 270	1-1/4	11	1-1/2	2	

### COMBINATION PACKS CAPSULES AND A307 ROD ASSEMBLIES



Part No.	Size Capsule/Rod	Drill Size	Pkg. Qty.	Price /C
ADHC 10R	C10 / 3/8 X 5	1/2"	10	
ADHC 12R	C12 / 1/2 X 6	5/8"	10	
ADHC 16R	C16 / 5/8 X 7	3/4"	10	
ADHC 20R	C20 / 3/4 X 10	7/8"	10	

### ADDITIONAL ROD ASSEMBLIES LISTED ON P. 8

### ROD ADAPTORS

Part No.	Rod Size	Price /ea.
ADH A38F	3/8	
ADH A12F	1/2	
ADH A58F	5/8	
ADH A34F	3/4	
ADH A1F	1	
ADH A114F	1-1/4	

For use with SDS Drive tools or Adaptors

## ANCHOR ROD ASSEMBLIES FOR ADHESIVE ANCHORING

### ANCHOR ROD - Straight cut COMPLETE WITH NUT & WASHER



#### Zinc Plated A307 Steel

Part No.	Size	Pkg. Qty.	Case Qty.	Case Wt.	Price /C
PRA 383	3/8 x 3	10	100	10	
PRA 385	3/8 x 5	10	100	14	
PRA 126	1/2 x 6-1/2	10	100	37	
PRA 585	5/8 x 5	10	50	23	
PRA 587	5/8 x 7-1/2	10	50	31	
PRA 3410	3/4 x 10	10	-	12	
PRA 112	1 x 12	6	-	15	

#### Zinc Plated B7 High Strength Steel - 2H nut

PRA B7125	1/2 X 5	10	100	35
PRA B7126	1/2 X 6-1/2	10	100	37
PRA B7587	5/8 X 7-1/2	10	50	31
PRA B73410	3/4 X 10	10	10	12
PRA B7112	1 X 12	6	6	15

#### Stainless Steel Type 304

PRS4 385	3/8 x 5	10	100	14
PRS4 126	1/2 x 6-1/2	10	100	37
PRS4 587	5/8 x 7-1/2	10	50	31
PRS4 3410	3/4 x 10	10	10	12
PRS4 112	1 x 12	6	6	15

Also available: Type 316 stainless steel, galvanized, special length, and metric thread rod assemblies.

## ROD ASSEMBLIES - ANGLE CUT



#### Zinc Plated A307 Steel

Part No.	Size	Pkg. Qty.	Case Qty.	Case Wt.	Price /C
ADH R385	3/8 x 5	10	100	14	
ADH R126	1/2 x 6	10	100	37	
ADH R587	5/8 x 7	10	50	31	
ADH R3410	3/4 x 10	10	-	12	
ADH R112	1 x 12	6	-	15	
ADH R11416	1-1/4 x 16	6	-	32	

#### Zinc Plated B7 High

ADH B7126	1/2 X 6	10	100	37
ADH B7587	5/8 X 7	10	50	31
ADH B73410	3/4 X 10	10	-	12
ADH B7112	1 X 12	6	-	15

#### Stainless Steel Type 304

RS4 385	3/8 x 5	10	100	14
RS4 126	1/2 x 6	10	100	37
RS4 587	5/8 x 7	10	50	31
RS4 3410	3/4 x 10	10	-	12
RS4 112	1 x 12	6	-	15

Also available: Type 316 stainless steel, galvanized, special length, and metric thread rod assemblies.

## ROCKITE ANCHORING AND PATCHING CEMENT

- Pourable
- Expanding
- Permanent
- Versatile
- Economical
- Safe & Super-strong
- Fast-setting
- 50% stronger than cured concrete withing 1 hour



Rockite cement is a hydraulic type cement compound that is specially formulated to give superior strength and unsurpassed bonding qualities. When mixed with water, Rockite pours smoothly into place. It sets within 15 minutes. Within one hour, it develops a compressive strength of 4500 Psi. When fully set, ROCKITE grips metal to concrete permanently.

Use Rockite for:  
**ANCHOR BOLTS**      **SELF LEVELLING GROUT PATCHING**  
**SIGNS**                      **POSTS**  
**RAILING**                    **SEATS**  
**MACHINES**

Case Part No.	Size	Price	Qty.	/ea.
ROC 1	1-lb carton		12	
ROC 5	5-lb carton		4	
ROC 10	10-lb pail		4	
ROC 50	50-lb pail		1	

## ROCKITE X FOR USE WHERE EXPOSED TO STANDING WATER

ROCX 50	50-lb pail	1
---------	------------	---

## ROD COUPLINGS

### Zinc Plated

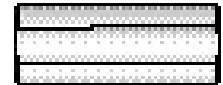

Part No.	Size	Length	A/F	Pkg. Qty.	Case Qty.	Case Wt.	Price /C
ROD 14	1/4 - 20	7/8	3/8	100	1,000	20	
ROD 516	5/16 - 18	1-1/8	1/2	100	1,000	47	
ROD 38	3/8 - 16	1-1/8	1/2	100	1,000	38	
ROD 38L	3/8 - 16	1-3/4	5/8	100	600	69	
ROD 12	1/2 - 13	1-3/4	11/16	50	300	36	
ROD 58	5/8 - 11	2-1/8	13/16	25	150	28	
ROD 34	3/4 - 10	2-1/4	1	25	150	45	

## REDUCER COUPLINGS

ROD 3814	3/8 - 1/4 x 1	100	1,000	40
----------	---------------	-----	-------	----

## BULK CARTONS

Part No.	Size	Length	A/F	Case Qty.	Case Wt.	Price /C
ROD 14B	1/4 - 20	7/8	3/8	2,800	53	
ROD 516B	5/16 - 18	1-1/8	1/2	1,200	55	
ROD 38B	3/8 - 16	1-1/8	1/2	1,300	48	
ROD 38LB	3/8 - 16	1-3/4	5/8	450	51	
ROD 12B	1/2 - 13	1-3/4	11/16	450	51	
ROD 58B	5/8 - 11	2-1/8	13/16	250	44	
ROD 34B	3/4 - 10	2-1/4	1	150	45	

## REDUCER COUPLINGS

ROD 3814	3/8 - 1/4 x 1	1,400	-
----------	---------------	-------	---

## WEDGE ANCHORS

- Carbon Steel
- Full Thread Design
- Letter Coded Studs



### Zinc Plated

Part No.	Size	Pkg. Qty.	Case Qty.	Case Wt.	Price /C
WED 14134	1/4 x 1-3/4	100	800	27	
WED 14214	1/4 x 2-1/4	100	800	31	
WED 14314	1/4 x 3-1/4	100	800	38	
WED 38214	3/8 x 2-1/4	50	400	35	
WED 38234	3/8 x 2-3/4	50	400	40	
WED 383	3/8 x 3	50	400	42	
WED 38334	3/8 x 3-3/4	50	400	49	
WED 385	3/8 x 5	100	300	45	
WED 12234	1/2 x 2-3/4	50	150	29	
WED 12334	1/2 x 3-3/4	50	150	35	
WED 12414	1/2 x 4-1/4	50	150	38	
WED 12512	1/2 x 5-1/2	50	150	47	
WED 127	1/2 x 7	25	75	31	
WED 12812	1/2 x 8-1/2	25	75	36	
WED 1210	1/2 x 10	25	75	43	
WED 58312	5/8 x 3-1/2	25	75	31	
WED 58412	5/8 x 4-1/2	25	75	36	
WED 585	5/8 x 5	25	75	40	
WED 586	5/8 x 6	25	75	44	
WED 587	5/8 x 7	20	60	52	
WED 58812	5/8 x 8-1/2	20	60	61	
WED 5810	5/8 x 10	15	45	47	
WED 34414	3/4 x 4-1/4	20	60	52	
WED 34434	3/4 x 4-3/4	20	60	55	
WED 34512	3/4 x 5-1/2	20	60	50	
WED 34614	3/4 x 6-1/4	15	45	54	
WED 347	3/4 x 7	15	45	45	
WED 34812	3/4 x 8-1/2	10	30	53	
WED 3410	3/4 x 10	10	30	42	
WED 3412	3/4 x 12	10	30	49	
WED 786	7/8 x 6	10	30	38	
WED 788	7/8 x 8	10	30	48	
WED 7810	7/8 x 10	5	15	39	
WED 16	1 x 6	10	30	47	
WED 19	1 x 9	5	15	46	
WED 112	1 x 12	5	15	59	
WED 1149	1-1/4 x 9	4	12	56	
WED 11412	1-1/4 x 12	4	12	49	

### Galvanized Steel

WAG 38234	3/8 x 2-3/4	50	400	38	
WAG 38334	3/8 x 3-3/4	50	400	51	
WAG 12334	1/2 x 3-3/4	50	150	35	
WAG 12414	1/2 x 4-1/4	50	150	42	
WAG 12512	1/2 x 5-1/2	50	150	50	
WAG 58412	5/8 x 4-1/2	25	75	37	
WAG 586	5/8 x 6	25	75	45	
WAG 34414	3/4 x 4-1/4	25	75	52	
WAG 34512	3/4 x 5-1/2	20	60	50	
WAG 347	3/4 x 7	15	45	46	

## TIE WIRE ANCHORS

- New Design
- Heavier Head
- Easier to set

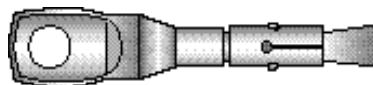

Part No.	Size	Eye Dia.	Pkg. Qty.	Case Qty.	Case Wt.	Price /C
EP 932	1/4 x 2	9/32	100	1,000	38	
EP932M	1/4 x 2	9/32	—	1,500	52	

## WEDGE ANCHORS

- Stainless Steel
- Type 304



Part No.	Size	Pkg. Qty.	Case Qty.	Case Wt.	Price /C
ISS 14134	1/4 x 1-3/4	100	800	27	
ISS 14214	1/4 x 2-1/4	100	800	31	
ISS 14314	1/4 x 3-1/4	100	800	38	
ISS 38214	3/8 x 2-1/4	50	400	35	
ISS 38234	3/8 x 2-3/4	50	400	40	
ISS 383	3/8 x 3	50	400	42	
ISS 38334	3/8 x 3-3/4	50	400	49	
ISS 385	3/8 x 5	100	300	45	
ISS 12234	1/2 x 2-3/4	50	150	29	
ISS 12334	1/2 x 3-3/4	50	150	35	
ISS 12414	1/2 x 4-1/4	50	150	38	
ISS 12512	1/2 x 5-1/2	50	150	47	
ISS 127	1/2 x 7	25	75	31	
ISS 58312	5/8 x 3-1/2	25	75	31	
ISS 58412	5/8 x 4-1/2	25	75	36	
ISS 586	5/8 x 6	25	75	44	
ISS 34414	3/4 x 4-1/4	20	60	52	
ISS 34512	3/4 x 5-1/2	20	60	50	
ISS 347	3/4 x 7	15	45	45	
ISS 3410	3/4 x 10	10	30	42	
ISS 16	1 x 6	10	30	47	
ISS 19	1 x 9	5	15	46	

### Stainless Steel Type 316

IST 14214	1/4 x 2-1/4	100	800	31	
IST 14314	1/4 x 3-1/4	100	800	38	
IST 38234	3/8 x 2-3/4	50	400	40	
IST 38334	3/8 x 3-3/4	50	400	49	
IST 385	3/8 x 5	100	300	45	
IST 12234	1/2 x 2-3/4	50	150	29	
IST 12334	1/2 x 3-3/4	50	150	35	
IST 12512	1/2 x 5-1/2	50	150	47	
IST 58412	5/8 x 4-1/2	25	75	36	
IST 586	5/8 x 6	25	75	44	
IST 34414	3/4 x 4-1/4	25	75	52	
IST 34512	3/4 x 5-1/2	20	60	50	
IST 347	3/4 x 7	15	45	45	

## MINIMUM EMBEDMENT FOR WEDGE ANCHORS

Size (inch)	1/4	3/8	1/2	5/8	3/4	7/8	1	1-1/4
Emb (inch)	1-1/8	1-5/8	2-1/4	2-3/4	3-1/4	4	4-1/2	5-1/2

## EYE LAG-SCREW

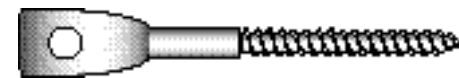

Part No.	Size	Eye Dia.	Case Qty.	Case Wt.	Price /M
ELS 143B	1/4 x 3	.210"	1,000	23	

## SETTING TOOL FOR EYE LAG-SCREW



Part No.	Price /ea.
DLS3	

## HEAVY-LOAD ANCHORS

Hex Bolt Type ISO Grade 8.8



### ZINC DICHROMATE PLATED

Part No.	Bolt dia. (mm)	Length (mm)	Min. Emb. (mm)	Drill Size (mm)	Fastens up to (mm)	Pkg. Qty.	Price /C
LHL 625	6	80	45	10	25	50	
LHL 650	6	100	45	10	50	50	
LHL 825	8	90	55	12	25	50	
LHL 850	8	115	55	12	50	25	
LHL 1025	10	100	65	14	25	25	
LHL 1050	10	125	65	14	50	25	
LHL 1225	12	115	80	18	25	20	
LHL 1240	12	130	80	18	40	20	
LHL 1625	16	140	100	24	25	10	
LHL 1650	16	160	100	24	50	10	
LHL 2030	20	170	125	28	30	10	
LHL 2060	20	200	125	28	60	5	

### Stainless Steel A4 (TYPE 316) with Titanium

LHS 825	8	90	55	12	25	50	
LHS 1025	10	100	65	14	25	25	
LHS 1050	10	125	65	14	25	25	
LHS 1215	12	105	80	18	15	20	
LHS 1240	12	130	80	18	40	20	
LHS 1625	16	140	100	24	25	25	
LHS 2030	20	170	125	28	30	10	

### STUD TYPE

Zinc Dichromate Plated ISO Grade 8.8



Part No.	Bolt dia. (mm)	Length (mm)	Min. Emb. (mm)	Drill Size (mm)	Fastens up to (mm)	Pkg. Qty.	Price /C
• BHL 825	8	100	55	12	25	50	
• BHL 1025	10	115	65	14	25	25	
• BHL 1050	10	140	65	14	50	25	
BHL 1225	12	130	80	18	25	20	
• BHL 1240	12	145	80	18	40	20	
BHL 1625	16	160	100	24	25	10	
• BHL 1650	16	180	100	24	50	10	
BHL 2030	20	190	125	28	30	10	
• BHL 2060	20	220	125	28	60	5	

### Stainless Steel Type 316 - A4 with Titanium

• BHS 825	8	90	55	12	25	50	
• BHS 1050	10	125	65	14	50	25	
• BHS 1215	12	105	80	18	15	20	
• BHS 1240	12	130	80	18	40	20	
• BHS 1625	16	140	100	24	25	25	
• BHS 2030	20	170	125	28	30	10	

• Special order item - limited stock - allow 2-6 weeks for delivery  
Also available special sizes & head styles  
Prices & delivery on request

## DROP-IN ANCHORS

Zinc Plated



Metric O/D

Part No.	Thread Size	Drill Size	Pkg. Qty.	Case Qty.	Case Wt	Price /C
IPA 14516	1/4	8MM	100	2,000	29	
IPA 381532	3/8	12MM	50	1,000	53	
IPA 582532	5/8	20MM	25	200	46	

Fractional O/D

IPA 1438	1/4	3/8	100	2,000	45	
IPA 3812	3/8	1/2	50	1,000	61	
IPA 1258	1/2	5/8	50	500	58	
IPA 5878	5/8	7/8	25	100	32	
IPA 341	3/4	1	25	100	49	

Stainless Steel Type 304

IPS 1438	1/4	3/8	100	2,000	42	
IPS 3812	3/8	1/2	50	1000	61	
IPS 1258	1/2	5/8	50	500	56	
IPS 5878	5/8	7/8	25	200	60	
IPS 341	3/4	1	25	100	49	

## COIL THREADED DROP-IN ANCHORS

Zinc Plated and Knurled

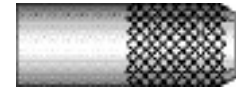

Part No.	Thread Size	Drill Size	Pkg. Qty.	Case Qty.	Case Wt	Price /C
CTD 1258	1/2	5/8	50	500	59	
CTD 341	3/4	1	25	100	49	

## SETTING TOOL FOR DROP-IN ANCHORS



Part No.	Anchor Size	Price /ea
IPAST 14	1/4	
IPAST 38	3/8	
IPAST 12	1/2	
IPAST 58	5/8	
IPAST 34	3/4	

## STUBi DROP-IN ANCHOR

3/8" Short Drop-in Anchor for Hollow Core Slabs and Other Shallow Embedment Requirements

• Zinc Plated Steel

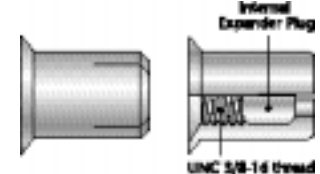

Part No.	Thread Size	Drill Size	Box. Qty.	Case Qty.	Price /C
DIS 3812	3/8"	1/2"	100	1000	

### SETTING TOOL FOR STUBi

Part No.	Anchor Size	Price/Each
DISST 38	3/8"	

## SLEEVE ANCHORS

### ACORN NUT

Zinc Plated

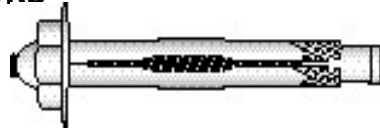

Part No.	Size	Pkg. Qty.	Case Qty.	Case Wt.	Price /C
SLE 14138	1/4 X 1-3/8	100	1,000	25	
SLE 14214	1/4 X 2-1/4	100	1,000	35	

### HEX NUT

Zinc Plated



Part No.	Size	Pkg. Qty.	Case Qty.	Case Wt.	Price /C
SLE 516112	5/16 x 1-1/2	100	1,000	40	
SLE 516212	5/16 x 2-1/2	100	600	36	
SLE 38178	3/8 x 1-7/8	50	500	36	
SLE 383	3/8 x 3	50	300	32	
SLE 12214	1/2 x 2-1/4	25	250	34	
SLE 123	1/2 x 3	25	150	26	
SLE 124	1/2 x 4	25	150	30	
SLE 126	1/2 x 6	25	100	30	
SLE 58214	5/8 x 2-1/4	25	150	38	
SLE 58414	5/8 x 4-1/4	10	60	26	
SLE 586	5/8 x 6	10	40	23	
SLE 34212	3/4 x 2-1/2	10	60	27	
SLE 34414	3/4 x 4-1/4	10	60	39	
SLE 34614	3/4 x 6-1/4	10	40	33	

### FLAT HEAD - PHILLIPS

Zinc Plated



Part No.	Size	Pkg. Qty.	Case Qty.	Case Wt.	Price /C
SLF 14138	1/4 x 1-3/8	100	1,000	19	
SLF 142	1/4 x 2	100	1,000	26	
SLF 143	1/4 x 3	100	1,000	36	
SLF 144	1/4 x 4	100	1,000	45	
SLF 14514	1/4 x 5-1/4	100	600	35	
SLF 516212	5/16 x 2-1/2	100	600	28	
SLF 516312	5/16 x 3-1/2	100	600	38	
SLF 38234	3/8 x 2-3/4	50	500	41	
SLF 384	3/8 x 4	50	300	33	
SLF 385	3/8 x 5	50	300	41	
SLF 386	3/8 x 6	50	300	49	

### HEX NUT

Stainless Steel

Type 304



Part No.	Size	Pkg. Qty.	Case Qty.	Case Wt.	Price /C
SLS 14138	1/4 x 1-3/8	100	1,000	23	
SLS 516112	5/16 x 1-1/2	100	1,000	39	
SLS 516212	5/16 x 2-1/2	100	600	34	
SLS 38178	3/8 x 1-7/8	50	500	33	
SLS 383	3/8 x 3	50	300	32	
SLS 123	1/2 x 3	25	150	27	

## SLEEVE ANCHORS

### BOLT HEAD TYPE WITH ISO GRADE 6.8 BOLT

Zinc Plated

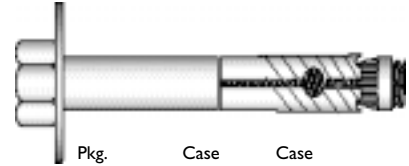

Part No.	Thread Size (mm)	Pkg. Qty.	Case Qty.	Case Wt.	Price /C
SLB 1040	10 X 40	50	500	40	
SLB 1060	10 X 60	50	500	45	
SLB 1080	10 X 80	50	300	34	
SLB 1255	12 X 55	25	250	37	
SLB 1270	12 X 70	25	250	41	
SLB 12100	12 X 100	25	150	33	

## LAG SHIELDS

Rust proof zamac alloy



### SHORT

Part No.	Size	Drill Size	Pkg. Qty.	Case Qty.	Case Wt.	Price /C
LAS 14	1/4 x 1	1/2	50	500	12	
LAS 516	5/16 x 1-1/4	1/2	50	500	13	
LAS 38	3/8 x 1-3/4	5/8	50	500	26	
LAS 12	1/2 x 2	3/4	25	250	21	

### LONG

Part No.	Size	Drill Size	Pkg. Qty.	Case Qty.	Case Wt.	Price /C
LAL 14	1/4 x 1-1/2	1/2	50	500	17	
LAL 516	5/16 x 1-3/4	1/2	50	500	16	
LAL 38	3/8 x 2-1/2	5/8	50	300	24	
LAL 12	1/2 x 3	3/4	25	150	19	

ALSO AVAILABLE IN BULK CARTONS

## SINGLE-EXPANSION SHIELDS

Rust proof zamac alloy



Part No.	Size	Drill Size	Pkg. Qty.	Case Qty.	Case Wt.	Price /C
USA 14	1/4	1/2	50	500	13	
USA 516	5/16	5/8	50	500	25	
USA 38	3/8	5/8	50	500	23	
USA 12	1/2	7/8	25	150	18	
USA 58	5/8	1	25	150	28	
USA 34	3/4	1-1/4	10	60	19	

ALSO AVAILABLE IN BULK CARTONS

## DOUBLE-EXPANSION SHIELDS

Rust proof zamac alloy

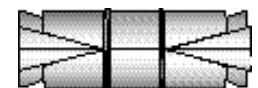

Part No.	Size	Drill Size	Pkg. Qty.	Case Qty.	Case Wt.	Price /C
UDA 14	1/4	1/2	100	1,000	29	
UDA 516	5/16	5/8	50	500	28	
UDA 38	3/8	3/4	50	300	28	
UDA 12	1/2	7/8	25	150	22	
UDA 58	5/8	1	25	150	31	
UDA 34	3/4	1-1/4	10	60	27	

ALSO AVAILABLE IN BULK CARTONS

## ZAMAC PIN BOLTS

With Zinc Plated Steel Nail

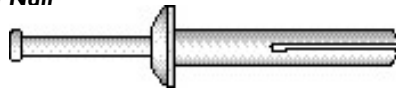

Part No.	Size	Pkg. Qty.	Case Qty.	Case Wt.	Price /C
ZAM 31678	3/16 X 7/8	100	1,000	15	
ZAM 141	1/4 X 1	100	1,000	19	
ZAM 14114	1/4 X 1-1/4	100	1,000	23	
ZAM 14112	1/4 X 1-1/2	100	1,000	26	
ZAM 142	1/4 X 2	100	1,000	32	
ZAM 143	1/4 X 3	100	1,000	40	

With Stainless Steel Nail

Part No.	Size	Pkg. Qty.	Case Qty.	Case Wt.	Price /C
ZAM 141SS	1/4 X 1	100	1,000	19	
ZAM 14114SS	1/4 X 1-1/4	100	1,000	23	
ZAM 14112SS	1/4 X 1-1/2	100	1,000	26	
ZAM 142SS	1/4 X 2	100	1,000	32	

## BULK PACK

With Zinc Plated Steel Nail

Part No.	Size	Case Qty.	Case Wt.	Price /M
ZAM 31678B	3/16 X 7/8	5,000	46	
ZAM 141B	1/4 X 1	2,500	48	
ZAM 14114B	1/4 X 1-1/4	2,000	45	
ZAM 14112B	1/4 X 1-1/2	1,800	46	
ZAM 142B	1/4 X 2	1,250	40	
ZAM 143B	1/4 X 3	700	31	

## NYLON PIN BOLTS

With Zinc Plated Steel Nail

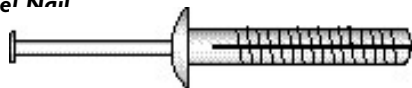

Part No.	Size	Head Style	Pkg. Qty.	Case Qty.	Case Wt.	Price /C
NYL 3161	3/16 X 1	M	100	1,000	5	
NYL 316112	3/16 X 1-1/2	R	100	1,000	7	
NYL 1434	1/4 X 3/4	M	100	1,000	5	
NYL 141	1/4 X 1	M	100	1,000	6	
NYL 14112	1/4 X 1-1/2	M	100	1,000	9	
NYL 142	1/4 X 2	M	100	1,000	11	
NYL 143	1/4 X 3	M	100	1,000	19	

ALSO AVAILABLE IN BULK CARTONS

With Nylon Nail

Part No.	Size	Head Style	Bag Qty.	Case Qty.	Bag Wt.	Price /C
NNY 1434M	1/4 X 3/4	M	1000	-	3	
NNY 141M	1/4 X 1	M	1000	-	4	
NNY 14112M	1/4 X 1-1/2	M	1000	-	5	

## UCAN ALEX

Extra-Grip Aluminum Plugs



Suitable for electrical fixtures and other fire rated installations

Part No.	Size	Screw Size	Pkg. Qty.	Case Qty.	Case Wt.	Price /C
ALE 121	1/4 X 1	6-10	100	1,000	3	
ALE 12114	1/4 X 1-1/4	6-10	100	1,000	3	
ALE 12112	1/4 X 1-1/2	6-10	100	1,000	4	

## NYLON DRIVE SCREW ANCHORS

- Install with a hammer - remove with a screwdriver
- High grade nylon 6 body resists high and low temperatures
- Assembled in phillips head screw nails
- Also available in stainless steel screw nail
- Collapsible body ensures positive clamping
- Lock-in feature avoids pre-expansion

### Round Head



Part No.	Drill dia. (in)	Length (mm)	Fastens up to (mm)	Pkg. Qty.	Case Qty.	Case Wt.	Price /C
MNA 530	5	30	5	100	2,400	19	
MNA 540*	5	40	15	100	2,400		
MNA 550	5	50	25	100	2,400	16	
MNA 635	6	35	10	100	2,400	22	
MNA 650	6	50	25	100	1,800	20	
MNA 670	6	70	45	100	1,200	22	

### Countersink Head



Part No.	Drill dia. (in)	Length (mm)	Fastens up to (mm)	Pkg. Qty.	Case Qty.	Case Wt.	Price /C
MNA 850*	8	50	15	100	900		
MNA 860	8	60	25	100	900	21	
MNA 880	8	80	45	100	600	18	
MNA 8100	8	100	60	100	600	21	

### Mushroom Head

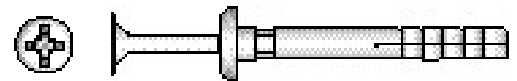

Part No.	Drill dia. (in)	Length (mm)	Fastens up to (mm)	Pkg. Qty.	Case Qty.	Case Wt.	Price /C
WAK 635	6	35	10	100	1,000	11	
WAK 645	6	45	20	100	1,000	13	
WAK 660	6	60	33	100	1,000	15	
WAK 670	6	70	42	100	600	12	

Always drill holes 6mm deeper than embedment.

\*New Size

## ZINC ALLOY SCREW ANCHORS



Part No.	Size	Drill Size	Pkg. Qty.	Case Qty.	Case Wt.	Price /C
LED 634	7-8 x 3/4	1/4	100	1,000	11	
LED 61	7-8 x 1	1/4	100	1,000	12	
LED 6112	7-8 x 1-1/2	1/4	100	1,000	20	
LED 101	10-12 x 1	5/16	100	1,000	20	
LED 10112	10-12 x 1-1/2	5/16	100	1,000	28	
LED 16112	14-16 x 1-1/2	3/8	100	1,000	40	

## MUNGO NYLON PLUGS HEAVY DUTY PUSH THROUGH TYPE



- Made of Nylon 6 for highest load performance
- Patented knock-in collar prevents premature expansion during installation
- Positive guidance keeps screw centered

Part No.	Size	Screw dia.	Drill (mm)	Pkg. Qty.	Case Qty.	Case Wt.	Price /C
MUN 5	5 X 25	4-6	5	100	9,600	8	
MUN 6	6 X 30	6-8	6	100	9,600	10	
MUN 8	8 X 40	10-12	8	100	4,800	15	
MUN 10	10 X 50	14-18	10	50	2,400	10	
MUN 12	12 X 60	3/8	12	25	1,200	10	
MUN 14B	14 X 70	M10	14	1000	1,000		

## MUNGO RENOVATION ANCHOR



These long length heavy duty anchors are supplied complete with screws. They can be used as wall tie anchors, spacing anchors, frame anchors, and for many other applications.

Part No.	Length	Drill (mm)	Pkg. Qty.	Price /C
MBS 1010	4	10	50	
MBS 1012	4-3/4	10	50	
MBS 1014	5-1/2	10	50	
MBS 1016	6-1/4	10	50	
MBS 1020	8	10	50	

Also available with stainless steel screws and lengths up to 300 mm.

## INSULATION FASTENERS ALL PLASTIC WITH 2-3/8" DIAMETER HEAD

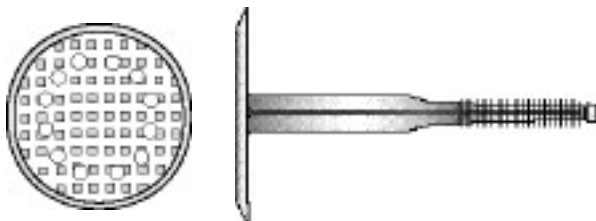

Part No.	Drill Size	Overall Length	Grip Range	Pkg. Qty.	Pkg. Wt.	Price /C
MJL 2	5/16	2	1/2-1	250	3	
MJL 234	5/16	2-3/4	1-1-1/2	250	3	
MJL 312	5/16	3-1/2	2-2-1/2	250	4	
MJL 414	5/16	4-1/4	2-1/2-3	250	5	

## EXTENDED GRIP RANGE 1-1/2" HEAD DIAMETER

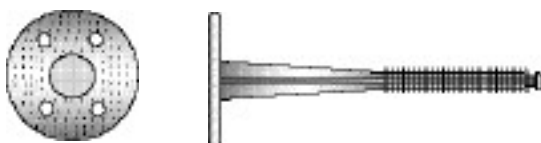

Part No.	Drill Size	Overall Length	Grip Range	Pkg. Qty.	Pkg. Wt.	Price /C
MJP 234	5/16	2-3/4	1 - 1-1/2	250	3	
MJX 3	5/16	3-1/4	1 - 2	400	5	
MJX 4	5/16	4-1/2	2 - 3-1/4	250	4	
MJP 5	5/16	5	3-1/2 - 4	250	5	
MJP 614	5/16	6-1/4	4-1/2 - 5	250	5	

## BLUE PLASTIC PLUGS

Economical plug for light loads in solid substrates

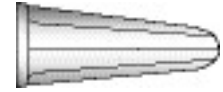

Part No.	Size	Drill Size	Pkg. Qty.	Case Qty.	Case Wt.	Price /C
UBP 68	6-8 X 3/4	3/16	100	1,000	1	
UBP 810	8-10 X 7/8	3/16	100	1,000	1	
UBP 1012	10-12 X 1	1/4	100	1,000	2	
UBP 1416	14-16 X 1-3/8	5/16	100	1,000	4	

ALSO AVAILABLE IN BULK CARTONS

## YELLOW PLASTIC PLUGS



- Primarily for solid substrates.
- Suitable for light loads in hollow walls.

Part No.	Size	Drill Size	Pkg. Qty.	Case Qty.	Case Wt.	Price /C
UYP 48	4-6-8 X 7/8	3/16	100	1,000	1	
UYP 812	8-10-12X1-1/4	1/4	100	1,000	2	
UYP 1216	12-14-16X1-1/2	5/16	100	1,000	3	

ALSO AVAILABLE IN BULK CARTONS

## PLUG JUGS

- Durable plastic jugs with easy access 4" opening
- Ideal for Tradesmen and Installers
- Lower cost than 100 packs
- 2 Ucan drill bits included in each jug



### BLUE PLUG JUGS

Part No.	Size	Drill	Jug Qty.	Case Qty.	Case Wt.	Price /Jug
UBP 810J	8-10 X 7/8	3/16	2,000	4	7	
UBP 1012J	10-12 X 1	1/4	1,000	4	4	

### YELLOW PLUG JUGS

Part No.	Size	Drill	Jug Qty.	Case Qty.	Case Wt.	Price /Jug
UYP 48J	4-8 X 7/8	3/16	2,000	4	7	
UYP 812J	8-12 X 1-1/4	1/4	850	4	7	

## METAL FRAME ANCHOR



- Galvanized and fire resistant.
- Allows easy spacing of frame.

Part No.	Size (mm)	Pkg. Qty.	Pkg. Wt.	Price /C
MMR 110	10 x 110	100	12	
MMR 130	10 x 130	100	10	

## UCAN TWISTER ZAMAC DRYWALL ANCHOR



- Install with a screwdriver - hand or cordless.
- No predrilling is required.
- Improved design JET 100 expands to hold more securely.
- Fixtures can be installed with #8 screws of any length.

Part No.	Description	Pkg. Qty.	Case Qty.	Case Wt.	Price /C
JET 90	Twister anchor	100	1,000	12	
JET 100	Twister anchor long	100	1,000	15	

## TWISTER NYLON DRYWALL ANCHOR



Part No.	Description	Pkg. Qty.	Case Qty.	Case Wt.	Price /Jug
JET NYL	Twister nylon anchor	100	1,000	4	
JET NYLP	Twister nylon anchor jug	200	1,200	15	

## NYLON TOGGLE ANCHOR USE WITH #8 or #10 Screws

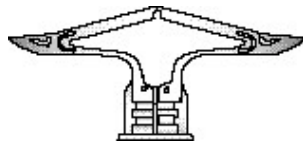

Part No.	Size	Drill Dia.	Grip Range	Pkg. Qty.	Case Qty.	Price /C
NTA 38	3/8	3/8	5/16-7/16	100	1000	
NTA 12	1/2	3/8	7/16-9/16	100	1000	
NTA 58	5/8	3/8	9/16-11/16	100	1000	

## KAP TOGGLE SNAP-OFF



Part No.	Screw Size	Drill Size	Box Qty.	Case Qty.	Price /C
KAP 316	3/16	1/2"	100	600	
KAP 316B	3/16	1/2"	500	-	
KAP 14	1/4	1/2"	100	600	
KAP 14B	1/4	1/2"	500	-	

## SCREWS FOR TOGGLE BOLTS SQUARE DRIVE/SLOT COMBE TRUSS HEAD SEE PAGE 24



## TOGGLE BOLTS WITH COMB



Part No.	Size	Drill Dia.	Pkg. Qty.	Case Qty.	Case Wt.	Price /C
TOG 182	1/8 X 2	3/8	50	500	8	
TOG 183	1/8 X 3	3/8	50	500	9	
TOG 184	1/8 X 4	3/8	50	500	12	
TOG 3162	3/16 X 2	9/16	50	500	16	
TOG 3163	3/16 X 3	9/16	50	500	18	
TOG 3164	3/16 X 4	9/16	50	500	21	
TOG 3165	3/16 X 5	9/16	50	300	16	
TOG 3166	3/16 X 6	9/16	50	300	18	
TOG 143	1/4 X 3	3/4	50	300	21	
TOG 144	1/4 X 4	3/4	50	300	24	
TOG 145	1/4 X 5	3/4	50	300	27	
TOG 146	1/4 X 6	3/4	50	300	29	
TOG 384	3/8 X 4	1	25	150	28	
TOG 385	3/8 X 5	1	25	100	21	
TOG 386	3/8 X 6	1	25	100	24	

## TOGGLE HEADS ONLY

Part No.	Size	Drill Dia.	Pkg. Qty.	Case Qty.	Case Wt.	Price /C
TOG H18	1/8	3/8	100	1,000	8	
TOG H316	3/16	1/2	100	1,000	15	
TOG H14	1/4	5/8	100	1,000	27	
TOG H38	3/8	1	100	1,000	29	

## METAL HOLLOW WALL ANCHORS WITH COMBINATION HEAD SCREWS

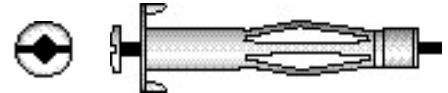

Part No.	Screw Size	Drill Dia.	Grip Range	Pkg. Qty.	Case Qty.	Case Wt.	Price /C
MWA 18XS	1/8 x 3/4	5/16	0-1/2	100	1,000	10	
MWA 18S	1/8 x 1-3/4	5/16	1/8-1/2	100	1,000	14	
MWA 18SL	1/8 x 3/4	5/16	1/8-3/4	100	1,000	14	
MWA 18L	1/8 x 1-3/4	5/16	5/8-7/8	100	1,000	19	
MWA 316S	3/16 x 2	7/16	1/8-5/8	50	500	18	
MWA 316L	3/16 x 2-1/2	7/16	5/8-1-1/4	50	500	24	
MWA 14S	1/4 x 2	1/2	1/8-5/8	50	500	24	
MWA 14L	1/4 x 2-1/2	1/2	5/8-1-1/4	50	500	30	

## DRIVE-TYPE ANCHORS

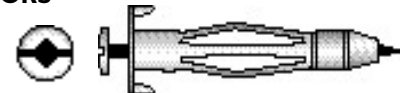

Part No.	Size	Grip Range	Pkg. Qty.	Case Qty.	Case Wt.	Price /C
MWD 18S	1/8 x 1-1/4	1/8-1/2	100	1,000	15	
MWD 18SL	1/8 x 1-3/4	1/8-3/4	100	1,000	15	
MWD 18L	1/8 x 1-3/4	5/8-7/8	100	1,000	19	

## MWA INSTALLATION TOOL Reduces Installation time by at least 50%



Part No.	Description	Price /EA
MWAT 1	MWA Installation Tool	

## SUPER SCRU-IT® MASONRY ANCHOR SYSTEM

- Exclusive scalloped threads cut deeper grooves in concrete
- Much higher holding power than other thread designs
- Completely stress free - may be installed close to edges
- Works where others fail in difficult substrates (e.g. horizontal mortar joints)
- Available with either straight shank or SDS drill systems
- Ruspro II coated for maximum corrosion resistance in exposed environments



New box with flip-out side for easy access.

### SUPER SCRU-IT® ANCHORS (Packages of 100)

One drill bit included with each 100 anchors



HEX WASHER-HEAD		PHILLIPS FLAT-HEAD			Price /C
Part No.	Size	Part No.	Case Qty.	Wt.	
SCH 31634	3/16 X 3/4	-----	1,000	7	
SCH 316114	3/16 X 1-1/4	SCP 316114	1,000	10	
SCH 316134	3/16 X 1-3/4	SCP 316134	1,000	12	
SCH 316214	3/16 X 2-1/4	SCP 316214	1,000	14	
SCH 316234	3/16 X 2-3/4	SCP 316234	1,000	17	
SCH 316314	3/16 X 3-1/4	SCP 316314	1,000	20	
SCH 3164	3/16 X 4	SCP 3164	1,000	23	
SCH 14114	1/4 X 1-1/4	SCP 14114	1,000	14	
SCH 14134	1/4 X 1-3/4	SCP 14134	1,000	19	
SCH 14214	1/4 X 2-1/4	SCP 14214	1,000	23	
SCH 14234	1/4 X 2-3/4	SCP 14234	1,000	27	
SCH 14314	1/4 X 3-1/4	SCP 14314	1,000	31	
SCH 144	1/4 X 4	SCP 144	1,000	37	
SCH 145	1/4 X 5	SCP 145	600	27	
-----		SCP 146	600	33	

### SUPER SCRU-IT® BULK PACKS

Drill bits not included

HEX WASHER-HEAD		PHILLIPS FLAT-HEAD			Price /M
Part No.	Size	Part No.	Case Qty.	Wt.	
SCH 31634B	3/16 X 3/4	-----	5,000	31	
SCH 316114B	3/16 X 1-1/4	SCP 316114B	4,000	36	
SCH 316134B	3/16 X 1-3/4	SCP 316134B	3,000	30	
SCH 316214B	3/16 X 2-1/4	SCP 316214B	2,000	25	
SCH 316234B	3/16 X 2-3/4	SCP 316234B	1,500	23	
SCH 316314B	3/16 X 3-1/4	SCP 316314B	800	16	
SCH 3164B	3/16 X 4	SCP 3164B	800	18	
SCH 14114B	1/4 X 1-1/4	SCP 14114B	2,500	32	
SCH 14134B	1/4 X 1-3/4	SCP 14134B	2,000	34	
SCH 14214B	1/4 X 2-1/4	SCP 14214B	1,500	33	
SCH 14234B	1/4 X 2-3/4	SCP 14234B	1,000	25	
SCH 14314B	1/4 X 3-1/4	SCP 14314B	800	24	
SCH 144B	1/4 X 4	SCP 144B	700	26	
SCH 145B	1/4 X 5	SCP 145B	600	27	

### SUPER SCRU-IT® SILVER (Packages of 100)

- One drill bit included with each 100 anchors
- Square Socket Drive
- Flat Countersink Head
- Silver Ruspro Coated



Part No.	Size	Bit Size	Fastens up to	Price /C
SCR 316114	3/16 X 1-1/4	#2	1/4"	
SCR 316134	3/16 X 1-3/4	#2	3/4"	
SCR 316214	3/16 X 2-1/4	#2	1-1/4"	
SCR 316234	3/16 X 2-3/4	#2	1-3/4"	
SCR 316314	3/16 X 3-1/4	#2	2-1/4"	
SCR 14114	1/4 X 1-1/4	#3	1/4"	
SCR 14134	1/4 X 1-3/4	#3	3/4"	
SCR 14214	1/4 X 2-1/4	#3	1-1/4"	
SCR 14234	1/4 X 2-3/4	#3	1-3/4"	
SCR 14314	1/4 X 3-1/4	#3	2-1/4"	

### SPECIAL SCRU-IT® (BLUNT TIP)

For Shallow Embedment Anchoring

Light Duty, Stress Free Fastener For Anchoring Applications Where Drilling Depth Is Limited to 7/8" (22 mm)

- Post-tensioned Slabs
- Hollow Core Slabs
- In-Floor Radiant Heating

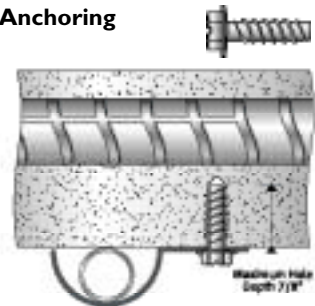

Part No.	Size	Pkg. Qty.	Case Qty.	Wt.	Price/C
SUH 1478	1/4 X 7/8	100	1,000	11	
SUH 1478B	1/4 X 7/8	BULK	4,000	11	

ONE DRILL BIT INCLUDED IN PACKAGE

#### Load Data

Part No.	Emb.	Hole/Bit Dia.	Ultimate Tension Load in 30 MPa Concrete
SUH 1478	3/4"	3/16"	800 LBF (3.56 KN)

### SCRU-IT® S.S.

410 STAINLESS STEEL RUSPRO COATED  
One drill bit included with each 100 anchors

#### HEX WASHER-HEAD

Part No.	Size	Pkg. Qty.	Case Qty.	Case Wt.	Price /C
SSH 14114	1/4 X 1-1/4	100	1,000	14	
SSH 14234	1/4 X 2-3/4	100	1,000	28	

#### PHILLIPS FLAT-HEAD

SSP 316114	3/16 X 1-1/4	100	1,000	8
SSP 316234	3/16 X 2-3/4	100	1,000	17

### TECHNICAL DATA - ULTIMATE LOADS

Fastener Diameter	Embed.	4000 psi concrete		Hollow Block		Working Loads
		Tension	Shear	Tension	Shear	
3/16	I	1,055	1,181	684	1,248	Application of a 4:1 safety factor is recommended
	I-1/2	2,033	n/a	n/a	n/a	
1/4	I	1,919	1,932	912	2,361	
	I-1/2	2,798	n/a	n/a	n/a	

## SCRU-IT® ACCESSORIES

### SCRU-TOOL

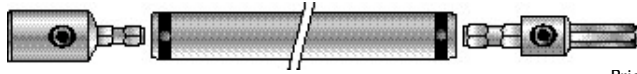

Part no.	Description	Price /ea
SCRUTOOL	Scru-It Installation Tool	

### SPARE PARTS FOR SCRUI-TOOL

CDP 1001	Drill Adaptor
CDP 1502	Sleeve (5-3/4")
CDP 1005	Long Sleeve (6-1/2")
CDP 1507	Extra-Long Sleeve (7-1/2")
CDP 1003	Detent Spring
CDP 1004	5/32" Ball Bearing
CDP 2008	1/8" Ball Bearing
CDP 1006	1/4" Driver Adaptor
CDP 1007	5/16" Driver Adaptor
CDP 1010	Phillips Driver Adaptor
CDP 2006	1/4"-28 Set Screw
CDP 2010	1/8" Hex Key

## SCRU-BITS®

High performance bits for concrete screw systems



Part no.	Size	Maximum Fastener Length	Price /ea
SCB 5323	5/32 X 3-1/2	1-3/4	
SCB 5324	5/32 X 4-1/2	2-3/4	
SCB 5325	5/32 X 5-1/2	4	
SCB 3163	3/16 X 3-1/2	1-3/4	
SCB 3164	3/16 X 4-1/2	2-3/4	
SCB 3165	3/16 X 5-1/2	4	
SCB 3166	3/16 X 6-1/2	5	
SCB 3167	3/16 X 7-1/2	6	

## BULK PACKS

Part no.	Size	Maximum Fastener Length	Pkg. Qty.	Price /C
SCB 5323B	5/32 X 3-1/2	1-3/4	100	
SCB 5324B	5/32 X 4-1/2	2-3/4	100	
SCB 5325B	5/32 X 5-1/2	4	100	
SCB 3163B	3/16 X 3-1/2	1-3/4	100	
SCB 3164B	3/16 X 4-1/2	2-3/4	100	
SCB 3165B	3/16 X 5-1/2	4	100	
SCB 3166B	3/16 X 6-1/2	5	100	
SCB 3167B	3/16 X 7-1/2	6	100	

## SDS SCRUI-BITS® WITH HEX FOR SCRUI-TOOL SLEEVE



Part no.	Size	Maximum Fastener Length	Price /EA.
SCS 5325	5/32 X 5-1/4	3/16 X 2-1/4	
SCS 5327	5/32 X 7	3/16 X 4	
SCS 3165	3/16 X 5-1/4	1/4 X 2-1/4	
SCS 3167	3/16 X 7	1/4 X 4	

**NOTE:** For 5" & 6" Lengths use IDS 9 - See P. 17

## PRECAST INSERTS

**3 NEW SIZES**

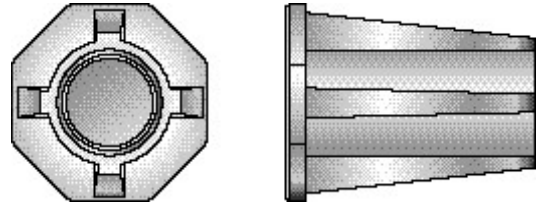

- **Ideal for use in precast units and poured-in-place concrete structures where fastener locations can be precisely planned.**
- **Made of rustproof zamac alloy to prevent surface staining.**
- **Install with bolts through holes in steel forms or by means of reusable concrete insert plugs on wood forms.**

Part No.	Length (in)	Thread Size	Pkg. Qty.	Case Qty.	Case Wt.	Price /C
PZI 10	11/16	10-24	100	4000	44	
PZI 15	1-1/2	1/4-20	100	800	41	
PZI 24	1	3/8-16	100	1000	44	
PZI 25	1-3/8	3/8-16	100	700	45	
PZI 35	1-1/2	1/2-13	50	300	40	
PZI 36	2-7/8	1/2-13	25	150	44	
PZI 45	1-11/16	5/8-11	25	200	38	
PZI 46	2-7/8	5/8-11	25	100	35	
PZI 55	1-11/16	3/4-10	25	150	33	
PZI 56	2-7/8	3/4-10	25	120	40	

### Over-tapped ASTM sizes for galvanized bolts

PZI 35OT*	1-1/2	1/2-13	50	300	40
PZI 45OT*	1-11/16	5/8-11	25	200	38
PZI 55OT*	1-11/16	3/4-10	25	150	33

## CONCRETE INSERT PLUG

Reusable nail-on insert plug for wood forms



Part No.	Thread Size	Box Qty.	Case Qty.	Case Wt.	Price /C
PZP 15	1/4-20	100	1,000	5	
PZP 25	3/8-16	100	1,000	6	
PZP 35	1/2-13	100	1,000	6	
PZP 45	5/8-11	100	1,000	8	
PZP 55	3/4-10	100	1,000	11	

## TECHNICAL INFORMATION

Size (in)	Base Width (in)	Full Thread Engagement	Installation Torque ft.lbs	Ultimate Tension Loads (4500 psi concrete)
1/4 x 1-1/2	13/16	7/8	2.6	2,243
3/8 x 1-3/8	7/8	1-1/8	8	2,900
1/2 x 1-1/2	1-1/4	1-1/4	19	6,690
1/2 x 2-7/8	1-3/8	2-1/2	19	n/a
5/8 x 1-11/16	1-3/8	1-3/8	40	9,650
3/4 x 1-11/16	1-9/16	1-1/2	58	8,200

## U-DRIVE® MASONRY ANCHOR SYSTEM

- Permanent and Cost Effective Anchoring
- Quick, easy installation without special tools
- Hot dip galvanized for maximum corrosion protection

- High pull out and shear strength
- F.M. approved for fastening roof insulation

### U-DRIVE ANCHORS



One Drill bit included with each 100 anchors

Part No.	Anchor Length	Fastens up to	Pkg. Qty.	Case Qty.	Case Wt.	Price /C
INS 118	1-1/8	1/8	100	1,000	14	
INS 112	1-1/2	1/2	100	1,000	20	
INS 2	2	1	100	1,000	24	
INS 212	2-1/2	1-1/2	100	1,000	29	
INS 3	3	2	100	1,000	33	
INS 312	3-1/2	2-1/2	100	1,000	40	
INS 4	4	3	100	1,000	44	
INS 412	4-1/2	3-1/2	100	600	30	
INS 5	5	4	100	600	32	

### BULK PACKS

Drill Bits not included

Part No.	Anchor Length	Fastens up to	Pkg. Qty.	Box Wt.	Case Wt.	Price /M
INS 118B	1-1/8	1/8	1,000	13	14	
INS 112B	1-1/2	1/2	1,000	16	17	
INS 2B	2	1	1,000	21	22	
INS 212B	2-1/2	1-1/2	1,000	26	27	
INS 3B	3	2	1,000	31	32	
INS 312B	3-1/2	2-1/2	1,000	38	39	
INS 4B	4	3	500	21	22	
INS 412B	4-1/2	3-1/2	500	23	24	
INS 5B	5	4	500	25	26	

### U-DRIVE TECHNICAL DATA AVERAGE ULTIMATE LOADS

Embedment (in)	3000 PSI Concrete		In Hollow Wall Concrete Block
	Pullout (lbs.)	Shear (lbs.)	Shear (lbs.)
3/4	749	n/a	576
1	1,214	2,270	843

### U-DRIVE DRILL BITS STRAIGHT SHANK



Part No.	Size	Maximum Fastener Length	Price /ea
IND 312	.202 X 3-1/2	2	
IND 412	.202 X 4-1/2	3	
IND 512	.202 X 5-1/2	4	
IND 612	.202 X 6-1/2	5	
IND 712	.202 X 7-1/2	6	
IND 812	.202 X 8-1/2	7	

### SDS BITS



Part No.	Size	Maximum Fastener Length
IDS 4	.202 X 4	1-1/2
IDS 6	.202 X 6	3-1/2
IDS 9	.202 X 9-1/2	7

### U-DRIVE STRESS PLATE REQUIRED WHEN FASTENING INSULATION



Part No.	Size	Type	Pkg. Qty.	Pkg. Wt.	Price /M
SP 1M	3 Round	Plastic	1,000	24	

Available in black and natural

### E.I.F.S. DISCS

- Made from high grade polymer for long service life
- Accepts screws and nails

#### TYPE PM

Universal disc for Polymer Modified (PM) and Modified PB EIFS to fasten rigid insulation to wood, steel, concrete, and masonry.



Part No.	Size	Pkg. Qty.	Pkg. Price /M
EID 134M	1-3/4 (45MM)	1,000	

#### TYPE PB

For installing Expanded Polystyrene (EPS) insulation board for Polymer based (PB) EIFS to wood, steel, concrete and masonry.

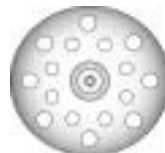

EIDS 2M	2 (50MM)	1,000	
---------	----------	-------	--

## LOW-VELOCITY TOOLS

### UCAN LV 360 SEMI-AUTOMATIC TOOL

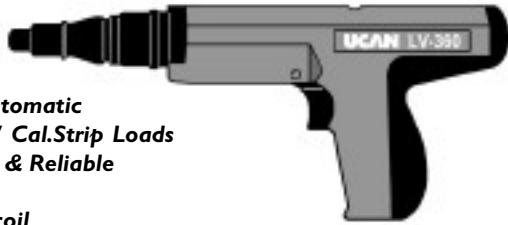

- Semi-Automatic
- Uses .27 Cal.Strip Loads
- Durable & Reliable
- Safe
- Low Recoil
- Low Noise Level
- Fasteners up to 2-1/2"
- Weighs only 5.2 lbs.

Complete Kit Includes Goggles, Ear Plugs, Cleaning Brushes, Wiper, Lubricant, Spare Parts, Training Manual and Heavy-Duty Carrying Case.

Part No.	Description	Price /ea.
LV 360K	Deluxe Tool Kit Complete	

#### FIELD REPLACEMENT PARTS FOR LV 360

301200	piston assembly for flathead fasteners
301030	piston for UN-UD fasteners
301208	piston ring for 301200 piston
301031	piston ring for 301030 piston
301009	base plate
301010	guide
301011	shear clip
301012	stop
301013	steel ball
301014	annular spring
LV 35G	spall guard

### UCAN LV 470 SEMI-AUTOMATIC TOOL



- Semi-Automatic
- Adjustable power dial
- Uses .27 Cal.Strip Loads
- Durable & Reliable
- Safe
- Low Recoil
- Low Noise Level
- For PC pins and UTS studs up to 2-1/2"
- Weighs only 7 lbs.

Complete Kit Includes Plastic Case, Goggles, Lubricant, 1-1/4" Steel Brush, Wood Brush, 5 Stop Rings, 3 Retaining Rings, Rod, Cleaning Cloth, Training Manual.

Part No.	Description	Price /ea.
LV 470K	Deluxe Tool Kit Complete	

#### FIELD REPLACEMENT PARTS FOR LV 470

C-05	stop ring
C-06	retaining ring, fastener guide
C-07	piston for pins
C-07A	piston for threaded studs
C-08	piston ring
C-09	piston guide
C-11	retaining ring, piston guide

### UCAN LV 151 TRACK TOOL



- Slide-action Track Tool
- Uses .22 cal.type A loads
- Less than 12" long; weighs only 4.4 lbs.

Complete kit includes Goggles, Ear Plugs, Cleaning Brushes, Wiper, Lubricant, Training Manual and Carrying Case.

Part No.	Description	Price /ea.
LV 151K	1-1/2 Capacity L.V. Tool Kit Complete	

#### FIELD REPLACEMENT PARTS FOR LV 151

PD2001	barrel extension
PD2003	piston & ring assembly
PD2004	piston ring
PD2021	barrel stop pin
PD2022	stop pin spring
PD2023	rubber buffer

#### ACCESSORIES FOR LV TOOLS

Part No.	Description	Price /ea.
LVCK	cleaning kit, (brushes, wiper, lub. spray)	
LVBR1	1-3/8 round brush	
LVBR2	5/8 round brush	
LVBR3	flat brush	
LVBR4	5/16 cleaning brush	
LVSPR	PAT tool spray lube 4FL.oz(118ml)	
LVSAFE	safety goggles	
LVCASE	carrying case	

## POWER LOADS FOR LOW-VELOCITY TOOLS

### .22 CAL. TYPE A FOR LV 151

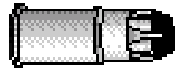

Part No.	Power Level	Pkg. Qty.	Case Qty.	Case Wt.	Price /C
CA1 GRA	gray 1 - lt	100	10,000	20	
CA2 BRO	brown 2 md.-lt	100	10,000	18	
CA3 GRE	green 3 md.-strong	100	10,000	18	
CA4 YEL	yellow 4 - strong	100	10,000	19	

### .27 CAL. LONG

C27LY	yellow - med	100	10,000	31	
C27LR	red - strong	100	10,000	34	
C27LP	purple - x strong	100	10,000	35	

## POWER LOADS FOR LOW-VELOCITY TOOLS

### .25 CAL. IN PLASTIC STRIPS FOR DX 35



Part No.	Power Level	Pkg. Qty.	Case Qty.	Case Wt.	Price /C
CTS GRE	green - light	100	10,000	26	
CTS YEL	yellow - med.	100	10,000	27	
CTS RED	red - strong	100	10,000	28	

### .27 CAL. IN PLASTIC STRIPS FOR UCAN LV360. ALSO FOR DX350 AND DX36.

CHS G	green - light	100	10,000	30	
CHS Y	yellow - med.	100	10,000	31	
CHS R	red - strong	100	10,000	32	

### FOR UCAN LV470 AND FOR DX450

CHS R	red - strong	100	10,000	32	
CHS P	purple - x strong	100	10,000	34	

## POWER LOAD DISCS .25 CAL. DISC

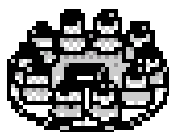

Part No.	Power Level	Pkg. Qty.	Case Qty.	Case Wt.	Price /C
CRD YEL	yellow - med.	100	5,000	20	

## CONDUIT CLIP ASSEMBLIES

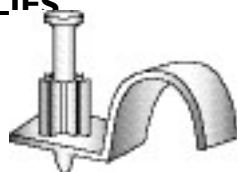

Part No.	Conduit Size	Pkg. Qty.	Case Qty.	Case Wt.	Price /C
FCC 12	1/2"	100	600	27	
FCC 34	3/4"	100	600	32	

## .300 FLAT-HEADED FASTENERS 5/16 FLUTED GUIDE WASHERS FOR STEEL AND CONCRETE

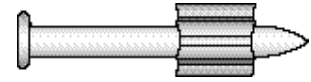

Part No.	Shank Length	Pkg. Qty.	Case Qty.	Case Wt.	Price /C
AFH 19	3/4	100	1,000	6	
AFH 25	1	100	1,000	7	
AFH 32	1-1/4	100	1,000	8	
AFH 37	1-1/2	100	1,000	9	
AFH 47	1-7/8	100	1,000	12	
AFH 57	2-1/4	100	1,000	14	
AFH 62	2-1/2	100	1,000	15	
AFH 72	3	100	1,000	17	

### Knurled for Steel

AFH 13K	1/2	100	1,000	5	
---------	-----	-----	-------	---	--

## TRACK PACKS

Part No.	Shank Length	Pkg. Qty.	Case Qty.	Case Wt.	Price /M
ATF 13K	1/2 knurled	1,000	1,000/Box	4	
ATF 19	3/4	1,000	6,000	36	
ATF 25	1	1,000	4,000	30	
ATF 32	1-1/4	1,000	1,000	9	

## SUPER POINT PINS FOR HEAVY STEEL AND CONCRETE

ASB 13	1/2 knurled	100	1,000	5	
ASB 16	5/8 knurled	100	1,000	5	
ASB 19	3/4	100	1,000	6	
ASB 22	7/8	100	1,000	7	
ASB 32	1-1/4	100	1,000	8	
ASB 47	1-7/8	100	1,000	12	

## SUPER POINT PINS WITH 25MM STEEL WASHER

Part No.	Shank Length	Pkg. Qty.	Case Qty.	Case Wt.	Price /C
AWI 32	1-1/4"	100	1,000	21	
AWI 37	1-1/2"	100	1,000	25	
AWI 50	2"	100	1,000	35	
AWI 62	2-1/2"	100	600	20	
AWI 75	3"	100	600	19	
AWI 32M	1-1/4"	1000	-	24	
AWI 37M	1-1/2"	1000	-	25	

## .300 FLAT-HEADED ANGLE CLIP ASSEMBLY

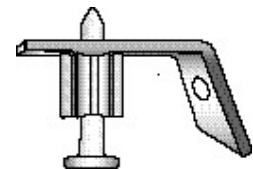

Part No.	Length	Pkg. Qty.	Case Qty.	Case Wt.	Price /C
ACC 32	1-1/4	100	1,000	42	

## .300 FLAT-HEADED "TOP HAT" FASTENERS



Part No.	Length	Pkg. Qty.	Case Qty.	Case Wt.	Price /C
FTH 19	3/4	100	1,000	7	

## 8 mm HEADED FASTENERS

Super Point with 8 mm Nylon Washer



FOR UCAN LV 360, \* ALSO FOR DX 350 & DX 36.

Part No.	Shank Length	Pkg. Qty.	Case Qty.	Case Wt.	Price /C
UD 19	3/4	100	1,000	6	
UD 22	7/8	100	1,000	6	
UD 27	1-1/8	100	1,000	7	
UD 32	1-1/4	100	1,000	8	
UD 37	1-1/2	100	1,000	9	
UD 47	1-7/8	100	1,000	11	
UD 57	2-1/4	100	1,000	13	
UD 62	2-1/2	100	1,000	15	
UD 72	3	100	1,000	16	

**Knurled for Steel**

UD 16K	5/8	100	1,000	5	
--------	-----	-----	-------	---	--

\* Piston 301050 required when UD pins are used in LV 360.

## 6 mm HEADED FASTENERS

Super Point with 12 mm Steel Washer

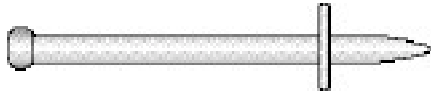

FOR UCAN LV 470, ALSO FOR DX 400 & DX 450.

Part No.	Shank Length	Pkg. Qty.	Case Qty.	Case Wt.	Price /C
PC 22	7/8	100	1,000	7	
PC 27	1-1/8	100	1,000	8	
PC 32	1-1/4	100	1,000	9	
PC 37	1-1/2	100	1,000	11	
PC 42	1-5/8	100	1,000	11	
PC 47	1-7/8	100	1,000	13	
PC 57	2-1/4	100	1,000	15	
PC 62	2-1/2	100	1,000	16	
PC 72	3	100	1,000	18	
PC 82	3-1/4	100	1,000	20	

**Knurled for Steel**

PC 16K	5/8	100	1,000	6	
PC 19K	3/4	100	1,000	7	

## 1/4"-20 THREADED STUDS

With Plastic Guide Washer and End Cap

FOR LV 360



Part No.	Thread Length	Shank Length	Pkg. Qty.	Case Qty.	Case Wt.	Price /C
U142012K	3/4	1/2 Knurled	100	1,000	11	
U142025	3/4	1	100	1,000	13	

with 12 MM plastic guide washer

FOR LV 470, (use C-07A Piston)



UTS 832K	1/2	1/2 Knurled	100	1,000	11	
UTS 1032K	3/4	7/16 Knurled	100	1,000	10	
UTS 1036K	3/4	9/16 Knurled	100	1,000	11	
UTS 245	3/4"	1	100	1,000	11	

## COMBO PACKS

PINS + LOADS

Sold only in units of 1,000 pins + 1,000 loads

### LV 151 COMBO TRACK PACKS

.300 PINS + .22 CAL "A" LOADS

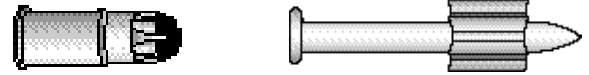

Part No.	Description	Pkg. Pins	Pkg. Loads	Case Qty.	Case Wt.	Price /M
ATF 13A3	1/2 pin + green	1,000	100	6,000	30	
ATF 19A2	3/4 pin + brown	1,000	100	6,000	34	
ATF 19A3	3/4 pin + green	1,000	100	6,000	34	
ATF 25A2	1 pin + brown	1,000	100	4,000	29	
ATF 25A3	1 pin + green	1,000	100	4,000	29	

### LV 360 COMBO PACKS

.300 PINS + .27 CAL. STRIP LOADS

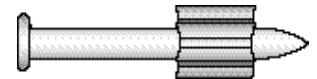

Part No.	Description	Pkg. Pins	Pkg. Loads	Case Qty.	Case Wt.	Price /M
ATF 13KSY	1/2 pin + yellow	1,000	100	6,000	31	
ASB 13SR	1/2 pin + red	100	100	1,000	31	
ATF 19SG	3/4 pin + green	1,000	100	6,000	35	
ATF 19SY	3/4 pin + yellow	1,000	100	6,000	35	
ATF 25SG	1 pin + green	1,000	100	4,000	30	
ATF 25SY	1 pin + yellow	1,000	100	4,000	30	
ATF 32SG	1-1/4 pin + green	1,000	100	1,000	10	
ATF 32SY	1-1/4 pin + yellow	1,000	100	1,000	10	
AFH 37SG	1-1/2 pin + green	100	100	1,000	12	
AFH 37SY	1-1/2 pin + yellow	100	100	1,000	12	
AFH 62SY	2-1/2 pin + yellow	100	100	1,000	17	
AFH 62SR	2-1/2 pin + red	100	100	1,000	17	

### D60 COMBO PACKS

.300 PINS & YELLOW DISC LOADS

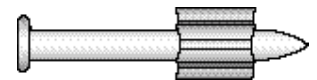

Part No.	Description	Pkg. Pins	Pkg. Loads	Price /M
ATF 13KRD	1/2 pin + disc	1,000	100	
ATF 19RD	3/4 pin + disc	1,000	100	
ATF 25RD	1 pin + disc	1,000	100	
ATF 37RD	1-1/2 pin + disc	100	100	
ATF 62RD	2-1/2 pin + disc	100	100	

## U-DRILLS BULK CASES SELF DRILLING METAL SCREWS

- U-Drills Self Drilling Screws are made to the highest industry quality standards for outstanding performance.
- All screws are available painted or protective coated to order.

\*New Part

### LIGHT - MEDIUM APPLICATIONS

#### SOCKET PAN HEAD

Zinc Plated

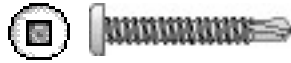

Part No.	Size	Point	Drilling Capacity	Case Qty.	Case Wt.	Price /M
TSP 638B	6-20 X 3/8	2	.090/13 ga	15,000	28	
TSP 612B	6-20 X 1/2	2	.090/13 ga	15,000	33	
TSP 812B	8-18 X 1/2	2	.100/12 ga	15,000	47	
TSP 858B	8-18 X 5/8	2	.100/12 ga	10,000	38	
TSP 834B	8-18 X 3/4	2	.100/12 ga	10,000	42	
TSP 81B	8-18 X 1	2	.100/12 ga	7,500	37	
TSP 8112B	8-18 X 1-1/2	2	.100/12 ga	6,000	44	
TSP 82B	8-18 X 2	2	.100/12 ga	3,000	27	
TSP 834BV*	8-18 X 3/4 White Hd		.100/12 ga	10,000	42	
TSP 1012B	10-16 X 1/2	2	.110/12 ga	10,000	45	
TSP 1058B	10-16 X 5/8	3	.175/7 ga	8,000	40	
TSP 1034B	10-16 X 3/4	3	.175/7 ga	8,000	45	
TSP 101B	10-16 X 1	3	.175/7 ga	5,000	35	
TSP 10114B	10-16 X 1-1/4	3	.175/7 ga	4,000	33	
TSP 10112B	10-16 X 1-1/2	3	.175/7 ga	4,000	39	

#### PHILLIPS PAN HEAD

Zinc Plated



Part No.	Size	Point	Drilling Capacity	Case Qty.	Case Wt.	Price /M
TPP 812B	8-18 X 1/2	2	.100/12 ga	15,000	46	
TPP 834B	8-18 X 3/4	2	.100/12 ga	10,000	42	
TPP 81B	8-18 X 1	2	.100/12 ga	7,500	39	
TPP 8112B	8-18 X 1-1/2	2	.100/12 ga	6,000	43	
TPP 1012B	10-16 X 1/2	2	.140/12 ga	10,000	46	
TPP 1034B	10-16 X 3/4	3	.175/7 ga	8,000	46	
TPP 101B	10-16 X 1	3	.175/7 ga	5,000	33	
TPP 10114B	10-16 X 1-1/4	3	.175/7 ga	4,000	33	

#### OVAL COUNTERSINK HEAD

Zinc Plated



Part No.	Size	Point	Drilling Capacity	Case Qty.	Case Wt.	Price /M
TPO 61B	6-20 X 1	2	.090/13 ga	15,000	51	
TSO 6114B	6-20 X 1-1/4	2	.090/13 ga	10,000	40	

#### PHILLIPS MODIFIED TRUSS HEAD

Zinc Plated



Part No.	Size	Point	Drilling Capacity	Case Qty.	Case Wt.	Price /M
TPW 812B	8-18 X 1/2	2	.100/12 ga	10,000	40	
TPW 8114B*	8-18 X 1-1/4	2	.100/12 ga	7,000	33	
TPW 1034B*	10-16 X 3/4	3	.175/7 ga	8,000	46	

### LIGHT - MEDIUM APPLICATIONS

#### HEX WASHER HEAD

Zinc Plated



Part No.	Size	Point	Drilling Capacity	Case Qty.	Case Wt.	Price /M
THW 812B	8-18 X 1/2	2	.100/12 ga	10,000	32	
THW 812BWWW	8-18 X 1/2 white/white heads			10,000	34	
THW 858B	8-18 X 5/8	2	.100/12ga	10,000	38	
THW 834B	8-18 X 3/4	2	.100/12 ga	10,000	43	
THW 81B	8-18 X 1	2	.100/12 ga	8,000	43	
THW 8112B	8-18 X 1-1/2	2	.100/12 ga	6,000	43	
THW 1012B	10-16 X 1/2	2	.140/12ga	10,000	48	
THW 1058B	10-16 X 5/8	3	.175/7 ga	8,000	42	
THW 1034B	10-16 X 3/4	3	.175/7 ga	8,000	46	
THW 101B	10-16 X 1	3	.175/7 ga	5,000	36	
THW 10114B	10-16 X 1-1/4	3	.175/7 ga	4,000	35	
THW 10112B	10-16 X 1-1/2	3	.175/7 ga	3,000	31	
THW 102B	10-16 X 2	3	.175/7 ga	2,000	25	
THW 10212B	10-16 X 2-1/2	3	.175/7 ga	1,500	22	
THW 103B	10-16 X 3	3	.175/7 ga	1,000	17	
THW 1234B	12-14 X 3/4	3	.210/5 ga	6,000	47	
THW 121B	12-14 X 1	3	.210/5 ga	5,000	46	
THW 12114B	12-14 X 1-1/4	3	.210/5 ga	3,000	33	
THW 12112B	12-14 X 1-1/2	3	.210/5 ga	3,000	40	
THW 122B	12-14 X 2	3	.210/5 ga	2,000	33	
THW 12212B	12-14 X 2-1/2	3	.210/5 ga	1,500	30	
THW 1434B	1/4-14 X 3/4	3	.220/4 ga	4,000	48	
THW 141B	1/4-14 X 1	3	.220/4 ga	4,000	42	
THW 14114B	1/4-14 X 1-1/4	3	.220/4 ga	2,000	34	
THW 14112B	1/4-14 X 1-1/2	3	.220/4 ga	2,000	38	
THW 142B	1/4-14 X 2	3	.220/4 ga	1,500	36	
THW 14212B	1/4-14 X 2-1/2	3	.220/4ga	1,000	28	
THW 143B	1/4-14 X 3	3	.220/4ga	1,000	34	
THW 144B	1/4-14 X 4	3	.220/4ga	500	19	

#### Ruspro II Coated

TRH 1034B	10-16 X 3/4	3	.175/7 ga	8,000	46
TRH 1234B	12-14 X 3/4	3	.210/5 ga	6,000	47
TRH 121B	12-14 X 1	3	.210/5ga	4,000	46
TRH 12114B	12-14 X 1-1/4	3	.210/5 ga	3,000	33
TRH 12112B	12-14 X 1-1/2	3	.210/5 ga	3,000	40
TRH 122B	12-14 X 2	3	.210/5 ga	2,000	33
TRH 141B	1/4-14 X 1	3	.220/4 ga	3,000	42
TRH 14201B	1/4-20 X 1	3	.220/4 ga	3,000	47
TRH 14112B	1/4-14 X 1-1/2	3	.220/4 ga	2,000	38

#### HEX WASHER HEAD

With Bonded EPDM Washer  
Zinc Plated



Part No.	Size	Point	Drilling Capacity	Case Qty.	Case Wt.	Price /M
THW 1034BN	10-16 X 3/4	3	.175/7 ga	3,000	26	
THW 1234BN	12-14 X 3/4	3	.210/5ga	3,000	32	
THW 121BN	12-14 X 1	3	.210/5 ga	3,000	37	
THW 12114BN*	12-14 X 1-1/4	3	.210/5 ga	2,000	28	
THW 12112BN	12-14 X 1-1/2	3	.210/5 ga	2,000	31	
THW 1434BN	1/4-14 X 3/4	3	.220/4 ga	3,000	47	
THW 141BN	1/4-14 X 1	3	.220/4 ga	2,000	42	
THW 14114BN	1/4-14 X 1-1/4	3	.220/4ga	2,000	45	
THW 14112BN	1/4-14 X 1-1/2	3	.220/4ga	1,000	23	
THW 142BN	1/4-14 X 2	3	.220/4 ga	1,000	38	

## U-DRILLS BULK CASES SELF DRILLING METAL SCREWS

### LIGHT-MEDIUM APPLICATIONS

#### STITCH LAPPING SCREW

Available with Bonded EPDM Washer



Zinc Plated

Part No.	Description	Point	Case Qty.	Case Wt.	Price /M
SHW 1478B	1/4-14 X 7/8 5/16 HWH	1	3,500	39	
SHWN 1478B	1/4-14 X 7/8 w/ EPDM washer	1	2,500	37	
SHW 1478LB	1/4-14 X 7/8-3/8 HWH	1	3,500	39	

### HEAVY GAUGE APPLICATIONS

#### HEX WASHER HEAD

Ruspro II Coated



Part No.	Size	Point	Drilling Capacity	Case Qty.	Case Wt.	Price /M
THW 1278B4	12-24 X 7/8	4	.312/ 5/16"	5,000	35	
THW 12114B5	12-24 X 1-1/4	5	.500/ 1/2"	4,000	45	
THW 12112B5	12-24 X 1-1/2	5	.500/ 1/2"	3,000	40	
THW 122B5	12-24 X 2	5	.500/ 1/2"	1,500	26	

### WOOD TO METAL APPLICATIONS

#### SOCKET WAFER HEAD WITHOUT REAMER

Zinc Plated



Part No.	Size	Point	Drilling Capacity	Case Qty.	Case Wt.	Price /M
TSW 1034B	10-24 X 3/4	3	.175/7 ga	8,000	45	
TSW 101B	10-24 X 1	3	.175/7 ga	5,000	36	
TSW 10114B	10-24 X 1-1/4	3	.175/7 ga	3,000	26	
TSW 10112B	10-24 X 1-1/2	3	.175/7 ga	3,000	31	
TSW 122B	12-24 X 2	3	.210/5 ga	1,500	29	
TSW 12212B	12-24 X 2-1/2	3	.210/5 ga	1,000	24	
TSW 123B	12-24 X 3	3	.210/5 ga	1,000	22	
TSW 124B	12-24 X 4	3	.210/5 ga	800	27	

#### SQUARE SOCKET WAFER HEAD WITH REAMER

Zinc Plated



Part No.	Size	Point	Drilling Capacity	Case Qty.	Case Wt.	Price /M
TSW 10112RB	10-24 X 1-1/2	3	.175/7 GA	3,000	30	
TSW 122RB	12-24 X 2	4	.312/5/16"	1,500	28	
TSW 12212RB	12-24 X 2-1/2	4	.312/5/16"	1,000	23	
TSW 123RB	12-24 X 3	4	.312/5/16"	1,000	27	
TSW 124RB	12-24 X 4	4	.312/5/16"	800	28	

### STAINLESS STEEL

#### SQUARE SOCKET PAN HEAD

410 Stainless Steel Hardened and Passivated



Part No.	Size	Point	Drilling Capacity	Case Qty.	Case Wt.	Price /M
TSP 812BSS	8-18 X 1/2	2	.100/12 ga	15,000	48	
TSP 1034BSS	10-16 x 3/4	3	.175/7 ga	8,000	47	

ALSO AVAILABLE WITH PHILLIPS HEAD

#### HEX WASHER HEAD



THW 812BSS	8-18 X 1/2	2	.100/12 ga	10,000	34	
THW 1034BSS	10-16 X 3/4	3	.175/7 ga	8,000	50	
THW 1234BSS	12-14 X 3/4	3	.210/5 ga	6,000	47	
THW 121BSS	12-14 X 1	3	.210/5 ga	5,000	43	
THW 1434BSS	1/4-14 X 3/4	3	.220/4 ga	4,000	49	
THW 141BSS	1/4-14 X 1	3	.220/4 ga	3,000	44	

### U-DRILLS - 100 PACKS

#### SOCKET PAN HEAD

Zinc Plated



Part No.	Size	Point	Drilling Capacity	Pkg. Qty.	Case Qty.	Case Wt.	Price /C
TSP 612	6-20 X 1/2	2	.090/13 ga	100	1,000	3	
TSP 812	8-18 X 1/2	2	.100/12 ga	100	1,000	5	
TSP 834	8-18 X 3/4	2	.100/12 ga	100	1,000	5	
TSP 81	8-18 X 1	2	.100/12 ga	100	1,000	6	
TSP 1012	10-16 X 1/2	2	.110/12 ga	100	1,000	5	
TSP 1034	10-16 X 3/4	2	.175/7 ga	100	1,000	7	
TSP 101	10-16 X 1	2	.175/7 ga	100	1,000	7	

#### HEX WASHER HEAD

Zinc Plated



THW 812	8-18 X 1/2	2	.100/12 ga	100	1,000	5	
THW 858	8-18 X 5/8	2	.100/12 ga	100	1,000	5	
THW 834	8-18 X 3/4	2	.100/12 ga	100	1,000	5	
THW 1012	10-16 X 1/2	2	.110/12 ga	100	1,000	6	
THW 1034	10-16 X 3/4	3	.175/7 ga	100	1,000	7	
THW 101	10-16 X 1	3	.175/7 ga	100	1,000	8	
THW 1234	12-14 X 3/4	3	.210/5 ga	100	1,000	9	
THW 121	12-14 X 1	3	.210/5 ga	100	1,000	11	
THW 1434	1/4-14 X 3/4	3	.220/4 ga	100	1,000	13	
THW 141	1/4-14 X 1	3	.220/4 ga	100	1,000	15	

# METAL FASTENERS



# UCAN

## U-DRILLS MAGNUM BUCKETS SELF DRILLING METAL SCREWS

### LIGHT - MEDIUM APPLICATIONS

#### SOCKET PAN HEAD

Zinc Plated



Part No.	Size	Point	Drilling Capacity	Pkg. Qty.	Case Qty.	Case Wt.	Price /M
TSP 612M	6-20 X 1/2	2	.090/13 ga	1000	6,000	13	
TSP 812M	8-18 X 1/2	2	.100/12 ga	1000	6,000	20	
TSP 858M	8-18 X 5/8	2	.100/12 ga	1000	6,000	23	
TSP 834M	8-18 X 3/4	2	.100/12 ga	1000	6,000	26	
TSP 81M	8-18 X 1	2	.100/12 ga	1000	6,000	32	
TSP 8112M	8-18 X 1-1/2	2	.100/12 ga	500	3,000	22	
TSP 1012M	10-16 X 1/2	2	.110/12 ga	1000	6,000	25	
TSP 1058M	10-16 X 5/8	3	.175/7 ga	1000	6,000	31	
TSP 1034M	10-16 X 3/4	3	.175/7 ga	500	3,000	18	
TSP 101M	10-16 X 1	3	.175/7 ga	500	3,000	22	

#### HEX WASHER HEAD

Zinc Plated



Part No.	Size	Point	Drilling Capacity	Pkg. Qty.	Case Qty.	Case Wt.	Price /M
THW 812M	8-18 X 1/2	2	.100/12 ga	1000	6,000	21	
THW 858M	8-18 X 5/8	2	.100/12 ga	1000	6,000	26	
THW 834M	8-18 X 3/4	2	.100/12 ga	1000	6,000	26	
THW 81M	8-18 X 1	2	.100/12 ga	1000	6,000	32	
THW 8112M	8-18 X 1-1/2	2	.100/12 ga	500	3,000	22	
THW 1012M	10-16 X 1/2	2	.100/12 ga	1000	6,000	29	
THW 1058M	10-16 X 5/8	3	.175/7 ga	1000	6,000	32	
THW 1034M	10-16 X 3/4	3	.175/7 ga	500	3,000	19	
THW 101M	10-16 X 1	3	.175/7 ga	500	3,000	22	
THW 10114M	10-16 X 1-1/4	3	.175/7 ga	500	3,000	25	
THW 10112M	10-16 X 1-1/2	3	.175/7 ga	300	1,800	19	
THW 1234M	12-14 X 3/4	3	.210/5 ga	500	3,000	26	
THW 121M	12-14 X 1	3	.210/5 ga	500	3,000	28	
THW 12112M	12-14 X 1-1/2	3	.210/5 ga	300	1,800	23	
THW 122M	12-14 X 2	3	.210/5 ga	250	1,500	14	
THW 1434M	1/4-14 X 3/4	3	.220/4 ga	300	1,800	22	
THW 141M	1/4-14 X 1	3	.220/4 ga	300	1,800	43	
THW 14114M	1/4-14 X 1-1/4	3	.220/4 ga	300	1,800	49	
THW 14112M	1/4-14 X 1-1/2	3	.220/4 ga	250	1,500	31	

#### PHILLIPS MODIFIED TRUSS HEAD

Zinc Plated



Part No.	Size	Point	Drilling Capacity	Pkg. Qty.	Case Qty.	Case Wt.	Price /M
TPW 812M	8-18 X 1/2	2	.100/12 ga	1,000	6,000	28	

### SHARP POINT SCREWS



Part No.	Head Style	Size	Pkg. Qty.	Case Qty.	Case Wt.	Price /M
STH 8916M	HWH	8 x 9/16	1,000	12,000	42	
STP 8916M	soc.pan	8 x 9/16	1,000	12,000	42	

### WOOD TO METAL APPLICATIONS

#### SOCKET WAFER HEAD

Twin lead fading thread  
Zinc Plated



Part No.	Size	Point	Drilling Capacity	Pkg. Qty.	Case Qty.	Case Wt.	Price /M
TSW 1034M	10-24 X 3/4	3	.175/7 ga	500	3,000	29	
TSW 101M	10-24 X 1	3	.175/7 ga	500	3,000	38	
TSW 10114M	10-24 X 1-1/4	3	.175/7 ga	300	1,800	26	

#### SQUARE SOCKET WAFER HEAD REAMER SCREWS

Zinc Plated



TSW 10112RM	10-24 X 1-1/2R	3	.175/7 ga	300	3,000	31	
TSW 122RM	12-24 X 2R	4	.312/5/16"	200	1,200	29	
TSW 12212RM	12-24 X 2-1/2R	4	.312/5/16"	150	900	37	

### HEAVY GAUGE APPLICATIONS

#### HEX WASHER HEAD

Ruspro II Coated



Part No.	Size	Point	Drilling Capacity	Pkg. Qty.	Case Qty.	Case Wt.	Price /M
THW 1278M4	12-24 X 7/8	4	.312/ 5/16"	500	5,000	43	
THW 12114M5	12-24 X 1-1/4	5	.500/ 1/2"	500	4,000	49	
THW 12112M5	12-24 X 1-1/2	5	.500/ 1/2"	300	3,000	44	
THW 122M5	12-24 X 2	5	.500/ 1/2"	250	1,500	27	

### STAINLESS STEEL

#### SOCKET PAN HEAD

410 Stainless Steel Hardened and Passivated



Part No.	Size	Point	Drilling Capacity	Pkg. Qty.	Case Qty.	Case Wt.	Price /M
TSP 812MSS	8-18 X 1/2	2	12 ga	1,000	15,000	30	
TSP 1034MSS	10-16 x 3/4	2	7 ga	500	8,000	47	

ALSO AVAILABLE WITH PHILLIPS HEAD

#### HEX WASHER HEAD



THW 812MSS	8-18 X 1/2	2	12 ga	500	5,000	18	
THW 1034MSS	10-16 X 3/4	3	7 ga	500	8,000	24	
THW 1234MSS	12-14 X 3/4	3	5 ga	500	5,000	40	
THW 121MSS	12-14 X 1	3	5 ga	500	5,000	49	
THW 1434MSS	1/4-14 X 3/4	3	4 ga	300	3,000	38	
THW 141MSS	1/4-14 X 1	3	4 ga	300	3,000	42	

## SHARP POINT TYPE "S" FOR SHEET METAL INDUSTRY TWINFAST THREAD DESIGN

### HEX WASHER HEAD Zinc Plated



Part No.	Head Style	Size	Case Qty.	Case Wt.	Price /M
STH 638B*	hex	6 x 3/8	15,000	31	
STHS 8916B	hex/socket	8 x 9/16	10,000	33	
STH 8916B	hex	8 x 9/16	10,000	33	
STH 834B	hex	8 x 3/4	10,000	41	
STH 81B	hex	8 x 1	10,000	51	
STH 8114B	hex	8 x 1-1/4	7,000	43	
STH 8112B*	hex	8 x 1-1/2	5,000	49	
STH 1038B*	hex	10 x 3/8	10,000	43	
STH 1012B*	hex	10 x 1/2	10,000	48	
STH 1058B*	hex	10 x 5/8	8,000	42	
STH 102B*	hex	10 x 2	2,000	24	

### Painted Head

STH 638BW	hex/white	6 x 3/8	15,000	31	
STH 8916BW	hex/white	8 x 9/16	10,000	33	
STH 81BW	hex/white	8 x 1	10,000	51	
STH 8114BAW	hex/arctic white	8 x 1-1/4	7,000	43	
STH 8112BW	hex/white	8 x 1-1/2	7,000	49	
STH 102BW	hex/white	10 x 2	2,000	24	

### SOCKET PAN HEAD

#### Zinc Plated



STP 658B*	soc.pan	6 x 5/8	15,000	35	
STP 8916B	soc.pan	8 x 9/16	10,000	34	
STP 834B	soc.pan	8 x 3/4	10,000	42	
STP 81B	soc.pan	8 x 1	8,000	50	
STP 8114B	soc.pan	8 x 1-1/4	7,000	43	

### PHILLIPS MODIFIED TRUSS HEAD SHARP POINT

#### Zinc Plated



No.	Head Style	Size	Case Qty.	Case Wt.	Price Par t /M
SPW 8916B*	Phillips	8 X 9/16	10,000	30	
SPW 834B*	Phillips	8 X 3/4	10,000	49	
SPW 81B	Phillips	8 X 1	8,000	45	
SPW 8114B*	Phillips	8 X 1-3/4	5,000	33	
SPW 8112B*	Phillips	8 X 1-1/2	4,000	31	
SPW 82B*	Phillips	8 x 2	2,000	25	
SPW 8212B*	Phillips	8 X 2-1/2	2,000	24	
SPW 83B*	Phillips	8 x 3	1,000	33	

### Painted Head

SPW 8916BW	Phillips white	8 X 9/16	12,000	31	
SPW 834BW	Phillips white	8 X 3/4	10,000	43	
SPW 81BW	Phillips white	8 X 1	10,000	43	
SPW 8114BW	Phillips white	8 X 1-1/4	5,000	32	
SPW 8112BW	Phillips white	8 X 1-1/2	4,000	32	
SPW 82BW	Phillips white	8X 2	2,000	25	
SPW 8212BW	Phillips white	8 X 2-1/2	2,000	24	
SPW 83BW	Phillips white	8 x 3	1,000	33	
SPW 102BW	Phillips white	10 x 2	2,000	25	

### STAINLESS STEEL SHARP POINT

#### SOCKET PAN HEAD

#### 410 Stainless Steel Hardened & Passivated



Part No.	Head Style	Size	Case Qty.	Case Wt.	Price /M
STP 812BSS	soc.pan	8-18 x 1/2	10,000	32	

## METAL BUILDING SCREWS

### HEX WASHER HEAD

Twinfast thread design  
Ruspro I Coated

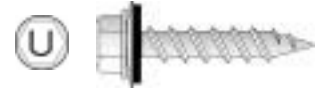

- Ruspro coated for extended corrosion protection
- Bonded EPDM washer for superior seal
- Fast drilling twinfast thread design
- Excellent paintability without the added cost of surface preparation
- Head identification stamp "U"

Part No.	Head Style	Size	Case Qty.	Case Wt.	Price /M
STH 101BN	hex	10 x 1	5,000	43	
STH 10112BN	hex	10 x 1-1/2	2,500	25	
STH 102BN	hex	10 x 2	2,000	29	
STH 10212BN	hex	10 x 2-1/2	1,800	30	
STH 103BN	hex	10 x 3	1,200	23	
STH 1434BN	hex	1/4 x 3/4	3,500	54	
STH 141BN	hex	1/4 x 1-	3,000	54	
STH 14114BN	hex	1/4 x 1-1/4	2,500	51	
STH 14112BN	hex	1/4 x 1-1/2	2,200	50	
STH 142BN	hex	1/4 x 2	1,500	41	
STH 14212BN	hex	1/4 x 2-1/2	1,100	36	
STH 143BN	hex	1/4 x 3	700	26	
STH 14312BN	hex	1/4 x 3-1/2	500	22	

### HEAD PAINTING

Fast efficient service. Prices on application.

## TOGGLE BOLT SCREWS

### Square Drive/Slot Combo Truss Head



Part No.	Size	Case Qty.	Price /M
TOS 182B	1/8 x 2	1,500	
TOS 182B	1/8 x 3	1,200	
TOS 3162B	3/16 x 2	1,500	
TOS 3163B	3/16 x 3	1,200	
TOS 3164B	3/16 x 4	800	
TOS 143B	1/4 x 3	1,200	
TOS 144B	1/4 x 4	800	
TOS 145B	1/4 x 5	500	
TOS 146B	1/4 x 6	300	
TOS 384B	3/8 x 4	600	
TOS 386B	3/8 x 6	300	

### Phillips Drive/Slot Combo Truss Head



TOP 3163B	3/16 x 3	1,200
TOP 3164B	3/16 x 4	800
TOP 144B	1/4 x 4	800

\*New Part

## CB SCREWS

### FOR CEMENTITIOUS SHEATHING PANELS

- Phillips wafer head with underside ribs
- Ruspro II corrosion resistant coated

## CB SPOON POINT SCREWS

### FOR WOOD STUDS AND LIGHT METAL STUDS UP TO 20GA

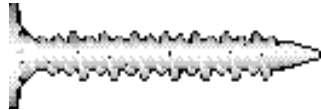

#### MAGNUM PACK

Part No.	Size	Pkg. Qty.	Case Qty.	Case Wt.	Price /M
CBS 114M	8 X 1-1/4	500	5,000	28	
CBS 158M	8 X 1-5/8	500	3,000	32	
CBS 214M	8 X 2-1/4	250	2,500	25	

#### BULK

CBS 114B	8 X 1-1/4	-	5,000	31	
CBS 158B	8 X 1-5/8	-	4,000	30	
CBS 214B	8 X 2-1/4	-	2,500	26	

## CB SELF DRILLING SCREWS

### FOR METAL STUDS UP TO 12GA



#### MAGNUM PACK

Part No.	Size	Pkg. Qty.	Case Qty.	Case Wt.	Price /M
CBT 114M	8 x 1-1/4	500	5,000	29	
CBT 158M	8 X 1-5/8	500	3,000	32	

#### BULK

CBT 114B	8 X 1-1/4	----	5,000	31	
CBT 158B	8 X 1-5/8	----	4,000	31	

## SEALING WASHERS - DISHED

Bonded EPDM - Zinc Galvanized - G90 Spe.

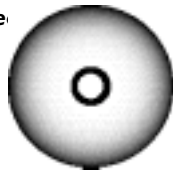

Part No.	Screw Size	Washer Dia.	Bag Qty.	Case Qty.	Price /M
SW 10B	10	12MM	500	25,000	
SW 1012B	10-12	14MM	500	15,000	
SW 14B	14	16MM	500	12,000	

#### Bonded EPDM - 18-8 Stainless Steel

Part No.	Screw Size	Washer Dia.	Bag Qty.	Case Qty.	Price /M
SW 1012BSS*	10-12	14MM	500	15,000	
SW 14BSS*	14	16MM	500	12,000	

## STRENGTH CHARACTERISTICS

Screw Size	Minimum Breaking Torque (in/lbs)	Tensile Strength (lbs)	Shear Strength (lbs)	Recommended Drilling Speed (rpm)
#6	30	1,102	652	1,800 - 2,200
#8	44	1,529	967	
#10	71	2,181	1,439	1,000 - 1,600
#12	97	3,305	2,068	
#14	160	4,563	2,540	

## DRILL POINT CAPABILITIES

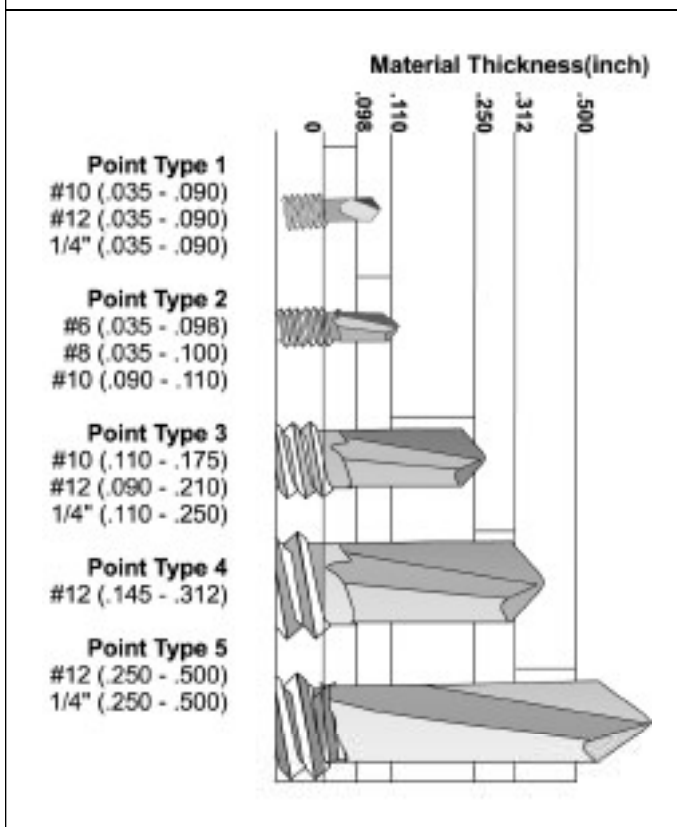

## CORROSION RESISTANT PROTECTIVE COATING

### ZINC CHROMATE PLATING

- clear zinc chromate
- thickness: 0.0002" - 0.0003"

### RUSPRO I

- withstands 500 hrs. salt spray to red rust
- organic coating
- self repairing
- paintable
- colour: silver/grey

### RUSPRO II

- withstands 1,000 hrs. salt spray to red rust
- multi-layer organic, ceramic coating
- high scratch resistance
- self-repairing
- resists galvanic corrosion
- thickness: 0.00005"
- colour: silver/grey

*Stainless Steel U-Drills available with Ruspro II coating.*

## SPECIAL COATING & ASSEMBLIES

*Available upon request.*

### PAINTED SCREW HEADS

"High solids" epoxy coating, in a wide range of colours, applied to screw heads.

### BONDED NEOPRENE WASHERING

GALVANIZED or STAINLESS STEEL bonded EPDM washers installed on #10, #12 & #14 screws.

## DISCLAIMER OF WARRANTIES AND LIABILITY

UCAN Fastening Products accepts no responsibility in case of any damage, loss or injury, direct, indirect, incidental or consequential that results from the use of, or the inability to use, the text and technical data contained in this or any subsequent editions and/ or versions of the Price List. Further, UCAN accepts no responsibility in case of damage that results from non-compliance with the manufacturer's installation instructions, improper sizing of anchor fastening by customer, inadequate load, bearing properties of anchoring base material, improper applications, or any other factors not brought to the attention of UCAN.

# TECHNICAL DATA



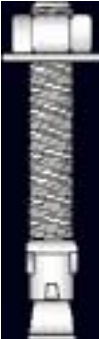

HEAVY LOAD ANCHOR LHL/LHS/BHL/BHS		INSTALLATION DATA			LOAD DATA IN 4000 psi (28 MPa) CONCRETE				
		SIZE (mm)	HOLE DIAMETER (mm)	EMBEDMENT (mm)	TORQUE (Nm)	ALLOWABLE LOADS (lbs)		ULTIMATE LOADS (lbs)	
						TENSION	SHEAR	TENSION	SHEAR
		6	10	45	10	1,190	1,601	4,180	5,605
		8	12	55	13	1,663	2,423	5,845	8,475
		10	14	65	16	2,338	3,754	8,183	13,151
		12	18	80	21	3,275	5,508	11,465	19,300
		16	24	100	26	6,070	9,577	21,130	33,500
		20	28	125	31	7,260	12,724	25,403	44,512

WEDGE ANCHOR WED/WAG/ISS/IST		INSTALLATION DATA			LOAD DATA IN 4000 psi (28 MPa) CONCRETE				
		SIZE (inch)	HOLE DIAMETER ( inch)	EMBEDMENT ( inch)	TORQUE (ft.lbs)	ALLOWABLE LOADS (lbs)		ULTIMATE LOADS (lbs)	
						TENSION	SHEAR	TENSION	SHEAR
		1/4	1/4	2-1/4	8	678	368	2,717	1,472
		3/8	3/8	3-3/8	28	1,301	789	5,203	3,151
		1/2	1/2	4-1/2	50	1,443	1,707	5,772	6,828
		5/8	5/8	5-5/8	75	2,324	2,415	9,294	9,659
		3/4	3/4	6-3/4	175	4,050	3,782	16,201	15,126
		7/8	7/8	8	225	5,072	5,394	20,288	21,574
		1	1	9	250	6,194	7,006	24,375	28,023
		1-1/4	1-1/4	6-1/2	350	5,773	9,150	23,090	36,600

DROP-IN ANCHOR IPA/IPS		INSTALLATION DATA			LOAD DATA IN 4000 psi (28 MPa) CONCRETE				
		SIZE (inch)	HOLE DIAMETER ( inch)	EMBEDMENT ( inch)	TORQUE (ft.lbs)	ALLOWABLE LOADS (lbs)		ULTIMATE LOADS (lbs)	
						TENSION	SHEAR	TENSION	SHEAR
		1/4	8mm	1	3	542	588	2,167	2,353
		3/8	1/2 (12mm)	1-1/2	12	990	1,037	3,960	4,147
		1/2	5/8	2	22	1,560	1,748	6,239	6,992
		5/8	3/4	2-1/2	55	2,165	2,767	8,661	11,068
		3/4	1	3	90	4,146	5,400	16,563	21,598

SLEEVE ANCHORS SLE/SLF/SLS		INSTALLATION DATA			LOAD DATA IN 4000 psi (28 MPa) CONCRETE				
		SIZE (inch)	HOLE DIAMETER ( inch)	EMBEDMENT ( inch)	TORQUE (ft.lbs)	ALLOWABLE LOADS (lbs)		ULTIMATE LOADS (lbs)	
						TENSION	SHEAR	TENSION	SHEAR
		1/4	1/4	1-1/8	5	240	357	959	1,428
		5/16	5/16	1-7/16	8	312	542	1,248	2,169
		3/8	3/8	1-1/2	15	406	766	1,625	3,064
		1/2	1/2	2-1/4	30	793	1,254	3,172	5,017
		5/8	5/8	2-3/4	58	1,139	2,130	4,556	8,522
		3/4	3/4	3-3/8	85	1,736	2,509	6,943	10,036

ADHESIVE CAPSULE ANCHORS (A307 rod) ADHC		INSTALLATION DATA			LOAD DATA IN 3500 psi (25 MPa) CONCRETE				
		SIZE (inch)	HOLE DIAMETER (inch)	EMBEDMENT (inch)	MAXIMUM TORQUE (ft.lbs)	ALLOWABLE LOADS (lbs)		ULTIMATE LOADS (lbs)	
						TENSION	SHEAR	TENSION	SHEAR
	3/8	1/2	3-1/4	15	1,023	819	4,903	3,275	
	1/2	5/8	4-1/4	30	2,128	1,276	8,510	5,106	
	5/8	3/4	5	60	3,394	2,038	13,578	8,154	
	3/4	7/8	6-3/4	110	4,999	2,999	19,995	11,997	
	1	1-3/16	8-1/4	185	9,091	5,454	36,363	21,818	
	1-1/4	1 1/2	12	295	14,531	8,719	58,125	34,875	

HAMMER CAP (A307 rod) HAC		INSTALLATION DATA			LOAD DATA IN 4500 psi (31 MPa) CONCRETE				
		SIZE (inch)	HOLE DIAMETER (inch)	EMBEDMENT (inch)	MAXIMUM TORQUE (ft.lbs)	ALLOWABLE LOADS (lbs)		ULTIMATE LOADS (lbs)	
						TENSION	SHEAR	TENSION	SHEAR
	3/8	7/16	3-1/2	15	1,162	698	4,650	2,790	
	1/2	9/16	4	30	2,129	1,277	8,514	5,108	
	5/8	3/4	5	60	3,390	2,034	13,560	8,136	
	3/4	1	6-3/4	110	5,010	3,006	20,040	12,024	
	7/8	1	6-1/2	135	5,810	4,158	23,238	16,632	
	1	1-1/8	8	185	8,714	5,454	34,854	21,816	
	1-1/4	1-1/2	13	295	14,535	8,721	58,140	34,884	

FLO-ROK FR5 (B7 rod)		INSTALLATION DATA			LOAD DATA IN 4000 psi (28 MPa) CONCRETE				
		SIZE (inch)	HOLE DIAMETER (inch)	EMBEDMENT (inch)	MAXIMUM TORQUE (ft.lbs)	ALLOWABLE LOADS (lbs)		ULTIMATE LOADS (lbs)	
						TENSION (BOND)	STEEL STRENGTH	TENSION (BOND)	STEEL STRENGTH
	3/8	1/2	3-1/2	15	1,480	1,395	5,920	5,580	
	1/2	5/8	4-1/2	30	2,267	2,554	9,067	10,217	
	5/8	3/4	5-1/2	60	3,607	4,068	14,427	16,272	
	3/4	7/8	6-1/2	110	4,993	6,012	19,973	24,048	
	7/8	1	7-1/2	135	6,627	8,316	26,507	33,264	
	1	1-1/8	8-1/2	185	7,693	10,908	30,773	43,632	

\*For FR5 MAX refer to pg. 6

FLO-ROK FR1 - FR3 (B7 rod)		INSTALLATION DATA			LOAD DATA IN 4000 psi (28 MPa) CONCRETE						
		SIZE (inch)	HOLE DIAMETER (inch)	EMBEDMENT (inch)	MAXIMUM TORQUE (ft.lbs)	ALLOWABLE LOADS (lbs)			ULTIMATE LOADS (lbs)		
						TENSION		SHEAR	TENSION		SHEAR
						FR1	FR3	FR1/ FR3	FR1	FR3	FR1/ FR3
	3/8	1/2	3-3/8	15	2,385	2,010	1,395	9,540	8,040	5,580	
	1/2	5/8	4-1/2	30	4,275	3,915	2,554	17,100	15,660	10,217	
	5/8	3/4	5-5/8	60	6,045	5,015	4,068	24,180	20,060	16,272	
	3/4	7/8	6-3/4	110	7,993	7,010	6,012	31,970	28,040	24,048	
	7/8	1	7-7/8	135	10,000	7,880	8,316	40,000	31,520	33,264	
	1	1-1/8	9	185	12,695	8,295	10,908	50,780	33,180	43,632	



Distributed by:



**UCAN FASTENING PRODUCTS**

155 Champagne Drive, Unit 10  
Toronto, Ontario M3J 2C6  
Tel.: 416-631-9400  
Fax: 416-631-9426  
E-mail: [sales@ucanfast.com](mailto:sales@ucanfast.com)  
[www.ucanfast.com](http://www.ucanfast.com)

